



MIXER DIRECT

INDUSTRIAL AGITATORS

By MXD Process

**Excellence in
every mix.**

PRODUCT BROCHURE

MXDPROCESS.COM



Here to help, from beginning to end.

We founded MXD Process on the belief that helping companies better serve their customers can change the world. We believe we make the world a little better when we help customers produce higher-quality products at a better price while consuming fewer resources. To bring this reality to life, we strive to be the most helpful company in the process engineering and equipment industry.

We do this by starting with a simple question, "What are you trying to make?" We dig into your process design and production methods to deeply understand your needs. We apply our process expertise to customize a solution to solve your challenge, not sell what products we have on the shelf. Our teams support you through installation and ramp-up so you can better serve your consumers.

Our broad range of process tanks, mixers, controls, mills, and accessories are designed in-house to meet your needs. Let's connect and work together to improve your process and make the world a little better every day.

MXD Process Products



EXCELLENCE IN EVERY MIX

Picking the right industrial mixing equipment is like choosing the secret ingredient that powers your company's success. That's exactly why businesses, from petroleum and pharmaceutical corporations to crafty startup breweries, trust our Mixer Direct mixers. It's not just about hitting targets; it's about diving deep into your processes to deliver the right mixing solution.

Here at MXD Process, we get how vital these components are in a process. That's why we strive to understand your needs and customize the right mixer for your budget.

We're not going to ask you what kind of mixer you want; we're going to ask you what you're trying to make. We won't sell you an oversized mixer off the shelf. We will design a mixer that uniquely meets your process needs.

Whether you're operating on a full facility scale or just starting out, we're here to help you nail down the perfect solutions to boost efficiency, smooth out your production line, and help you climb those manufacturing mountains.



Engineered for your success.



1000+ Gallon

Heavy Duty Mixers

Raiden Series Top Entry Mixers

The Raiden Series Mixers provide low to medium shear mixing in high volume applications. The Raiden mixer line is available from 1/2 HP to 100 HP servicing tanks from approximately 300 to 300,000 Gallons and up to 100,000 cps. The Raiden Standard, Plus, and MAXX mixers are designed to offer great lead times and pricing with customization available for a variety of mixing applications.



Raiden Standard
300- 3,000 Gallons

- Available with flange & plate mounts
- Customize shaft length up to 90"
- (2) 24"-38" low shear Hydrofoil Impellers
- Flanges equipped with Viton lip shaft seal
- 1/2 - 5HP Motors



Raiden Plus
50- 20,000 Gallons

- Available with flange & plate mounts
- Customize shaft length up to 144"+
- Use a variety of low to medium shear impellers
- Flanges available with Viton lip, PTFE lip, or mechanical seals
- 1/2 - 50HP Motors



Raiden Maxx
300- 3,000 Gallons

- Available with flange & plate mounts
- Customize shaft length up to 144"+
- Use a variety of low to medium shear impellers, any diameter
- Flanges available with lip, packing, and mechanical seals
- 1/2 - 100HP Motors



1000+ Gallon

Heavy Duty Mixers

Side Entry Mixers

Side entry mixers allow for mixing high volume applications at a reduced operating cost from a traditional top-entry mixer. Utilizing a shorter mixing shaft and our unique high efficiency fluid foil impeller, side entry tank mixers provide higher fluid flow per horsepower in high volume applications. Multiple side entry mixers can be used in one vessel to increase flow and turnover.



Standard Features

- Available with flange mounts
- Customize shaft length up to 40"
- (1) 12"-28" low shear, high efficiency fluid foil impeller
- Equipped with packing , single or double mechanical seal
- 2 - 75HP Motors

Simply the Right Mix

We offer many customization options to optimize your mixer for your unique process. Whether you're working in a hazardous environment or have strict industry regulations, we can meet your standards.

Common Customizations

- Explosion Proof Inverter Duty Motors
- Specialty Wetted Materials
- Sanitary Shaft & Impeller Polishes
- Pressure, Sanitary, & Temperature Rated Shaft Seals



5-1000 Gallon

Portable Mixers

Portable Top Entry Mixers

Designed for heavy-duty applications under 1,000 gallons, our portable top entry mixers include an extra support bearing, all-welded construction, and durable epoxy coatings to provide years of service across numerous industries. Available in standard ANSI flange mounts and plate mounts, these mixers attach directly to a tank or bridge over an open vessel.



Flange Mount

20-1,000 Gallons

- Available with electric, air, and XP inverter duty motors
- Geared and direct drive options
- Attaches to standard 2.5" 150# ANSI flanges
- Variable Frequency Drive (VFD) options
- Custom shaft lengths
- Sized with marine propeller or hydrofoil impeller



Plate Mount

20- 1,000 Gallons

- Available with electric, air, and XP inverter duty motors
- Geared and direct drive options
- Attaches with standard 12" x 12" plate
- Variable Frequency Drive (VFD) options
- Custom shaft lengths
- Sized with marine propeller or hydrofoil impeller



5-1000 Gallon

Portable Mixers

Clamp Mounted Mixers

The clamp mounted mixer is the work-horse of our portable mixer line. Available in an economy, heavy-duty, and sanitary stainless steel model, these mixers offer increased versatility in mixing applications over many other tank mounted mixers. Our clamp mount mixers are designed to be lightweight, yet robust, and easily attach to a mixer stand or side wall of a vessel.



Economy Clamp Mount

5- 1,000 Gallons

- Clamp opening up to 3.5", adjustable vertical positioning of mixer
- Available with Air & Electric Motors
- Variable Frequency Drive (VFD) options
- Custom shaft lengths available
- Sized with marine propeller or hydrofoil impeller

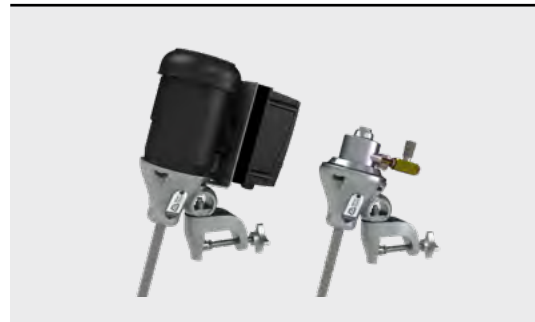

Heavy-Duty Clamp Mount

5- 1,000 Gallons

- Heavy duty clamp opening up to 3.5", adjustable vertical and horizontal positioning of mixer
- Available with Air, Electric, and XP Inverter Duty Motors
- Geared and direct drive options
- Variable Frequency Drive (VFD) options
- Custom shaft lengths available
- Sized with marine propeller or hydrofoil impeller.



Stainless Steel Clamp

5- 1,000 Gallons

- Stainless steel clamp and motor
- Available with Air & Electric Motors
- Geared and direct drive options
- Custom shaft lengths available
- Sized with marine propeller or hydrofoil impeller
- Specialty finishes available



5-1000 Gallon

Portable Mixers

Tri-Clamp Mixers

Popular in sanitary or sterile mixing processes, our tri-clamp mixers are available in a variety of models offering increased washdown capabilities in addition to efficient mixing. All standard tri-clamp mixers are equipped with a FDA lip shaft seal to prevent fluid loss or contamination in your mixing vessel. Attaches quickly and easily to standard tri-clamp fittings.



General Use Tri-Clamp Mount

5- 1,000 Gallons

- Available with Air, Electric, and XP Inverter Duty Motors
- Geared and direct drive options
- Variable Frequency Drive (VFD) options
- Custom shaft lengths available
- Sized with marine propeller or hydrofoil impeller



White Washdown Tri-Clamp Mount

5- 1,000 Gallons

- White washdown IP65 Electric Motor
- Geared and direct drive options
- Variable Frequency Drive (VFD) options
- Custom shaft lengths available
- Sized with marine propeller or hydrofoil impeller



Stainless Steel Tri-Clamp Mount

5- 1,000 Gallons

- Full stainless steel IP65 Electric Motor
- Available with Air & Electric Motors
- Geared and direct drive options
- Variable Frequency Drive (VFD) options
- Custom shaft lengths available
- Sized with marine propeller or hydrofoil impeller



250- 350 Gallon

IBC Tote Mixers

Tote Bracket Mixers

Our tote bracket mixers are optimized for mixing in standard IBC totes and similarly shaped vessels. Save time and money by processing directly in shipping and storage containers, or attach the bracket to open top tanks. Available with an economy or adjustable bracket.



Economy Tote Bracket Mount
250-350 Gallons

- Lightweight aluminum frame, 40" - 42" adjustable bracket width
- Available with Air, Electric, and XP Inverter Duty Motors
- Geared and direct drive options
- Variable Frequency Drive (VFD) options
- Sized with marine propeller, hydrofoil impeller, or folding turbine impeller



Tote Bracket Mount
250-350 Gallons

- Heavy duty epoxy coated steel frame, 36" - 54" adjustable bracket width
- Available with Air, Electric, and XP Inverter Duty Motors
- Geared and direct drive options
- Variable Frequency Drive (VFD) options
- Sized with marine propeller, hydrofoil impeller, or folding turbine impeller



55 Gallon

Drum Mixers

Drum Bracket Mixers

In order to minimize transfer waste and save capital investment, many manufacturers choose to do their processing in the drum they receive their product in. We've developed a line of drum agitators that attach in a variety of ways to the 55-gallon drum, each optimized for efficient low to medium shear mixing.



Drum Lid Mount
55 Gallons

- 24" carbon steel or stainless steel drum lid attaches with standard drum ring clamps
- Available with Air, Electric, and XP Inverter Duty Motors
- Geared and direct drive options
- Variable Frequency Drive (VFD) options
- Sized with marine propeller, hydrofoil impeller, or axial flow turbine



Drum Clamp Mount
55 Gallons

- Can be mounted to drum sidewall with or without drum lid attached
- Available with Air & Electric Motors
- Variable Frequency Drive (VFD) options
- Sized with marine propeller, hydrofoil impeller, or axial flow turbine



55 Gallon

Drum Mixers

Drum Bracket & Bung Mount

In order to minimize transfer waste and save capital investment, many manufacturers choose to do their processing in the drum they receive their product in. We've developed a line of drum agitators that attach in a variety of ways to the 55-gallon drum, each optimized for efficient low to medium shear mixing.



Drum Bracket Mount

55 Gallons

- Impeller and shaft fit through the center hole of a drum lid and mixer clamps securely around lid rim
- Lightweight aluminum frame
- Available with Air, Electric, and XP Inverter Duty Motors
- Geared and direct drive options
- Variable Frequency Drive (VFD) options
- Sized with marine propeller, hydrofoil impeller, or axial flow turbine

Common Customizations

- Explosion Proof Inverter Duty Motors
- Specialty Wetted Materials
- Sanitary Shaft & Impeller Polishes
- Pressure, Sanitary, & Temperature Rated Shaft Seals



Bung Mount

55 Gallons

- Threads on 2" NPT bung openings for mixing in closed vessels and drums
- Available with Air, Electric, and XP Inverter Duty Motors
- Geared and direct drive options
- Variable Frequency Drive (VFD) options
- Sized with marine propeller, hydrofoil impeller, or axial flow turbine



Lab Scale

Mixers & Stirrers

Electric Stirrers & Stand Packages

Optimized for mixing in small batch, laboratory settings, these stirrers are a great option for testing new processes or producing product with minimal capital investment. With an easy to use interface and a variety of mixing capabilities, numerous industries utilize these mixers in their facilities. Available as a standalone unit or a full package with stand, shaft and impeller.

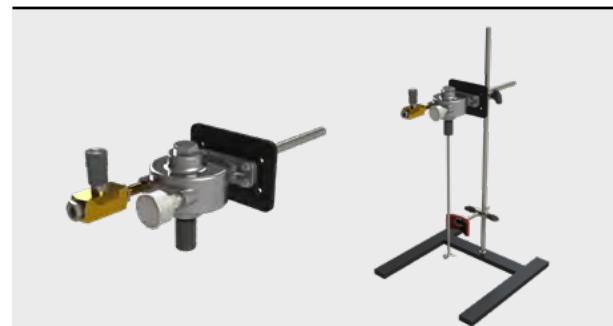

Air Stirrers & Stand Packages 200ml - 5 Gallons

- With amazing capabilities for its size, the air driven mixer can be used in formulation, R&D, clinical research, education labs, anywhere a magnetic stirrer is used. It fits into small spaces and can be easily transported to other labs or classrooms.



Ultra-Torque

Popular high torque model for creams, polymers, inks and mining pilot plants.



Universal

General purpose stirrer with versatility for buffers, media, gels, lotions and slurries.



Ultra-Speed

Provides the high speeds ideal for emulsions, homogenization, and high shear dispersion.



Reversing

Versatile programmable clockwise and counterclockwise stirring for gentler agitation.



Compact

Footprint optimal for limited bench space, reaction vessels and metallurgical leaching systems.



Stainless Steel

Mixer Impellers

Low, Medium, and High Shear Impellers

Impellers come in many configurations and sizes and accomplish a variety of different tasks in liquid processing. From low shear, gentle agitation to high speed, high shear dispersions, choosing the right impeller is critical for success in a mixing process. Our mixing impellers are constructed of 304 or 316 grade stainless steel for corrosion and abrasion resistance.



Marine Propeller
Low Shear

- Available in diameters up to 14"
- Bore sizes up to 1.5"
- Standard left hand pitch, steep pitch, and right hand pitch configurations.



High Efficiency Hydrofoil Impeller
Low Shear

- Available in diameters up to 40"
- Bore sizes up to 7.5"
- Higher pumping capacity per horsepower than marine propellers.



Folding Impeller
Medium Shear

- Available in diameters up to 14"
- Bore sizes up to 1"
- Designed to fold and slip through bung and NPT fittings. Opens when the motor is powered on.



Radial Flow Turbine
Medium Shear

- Available in diameters up to 24"
- Bore sizes up to 7.5"
- Imparts radial flow into processing.



Stainless Steel

Mixer Impellers

Customize Any Impeller to Meet Your Exact Process Needs



Axial Flow Turbine
Medium Shear

- Available in diameters up to 40"
- Bore sizes up to 7.5"
- Imparts axial flow into processing.



Dispersion Blade
High Shear

- Available in diameters up to 36"
- Bore sizes up to 5/8"
- Imparts high shear to break apart agglomerations, particle reduction, and homogenization.



High Flow Dispersion Blade
High Shear

- Available in diameters up to 34"
- Bore sizes up to 5/8"
- Provides higher flow than a standard dispersion blade by utilizing axial flow blades integrated in the dispersion blade.



Ultra Shear Dispersion Blade
High Shear

- Available in diameters up to 36"
- Bore sizes up to 5/8"
- Provides additional shear than standard dispersion blades by utilizing serrated tips along the perimeter of the blade.





WWW.MXDPROCESS.COM

4650 New Middle Road
Jeffersonville, IN 47130

812-202-4047
info@mxdprocess.com