

INSTALLATION, OPERATION, AND MAINTENANCE MANUAL
FOR
THE SHEARPRO LINE OF
BATCH ROTOR STATOR ECONOMY HOIST STANDS (EHS)

Congratulations on your purchase of a ShearPro Batch Rotor Stator Economy Hoist Stand from MXD Process. This manual will help with installation, set-up, operation, maintenance, repair, and provide general information about your unit. Read this manual in its entirety before setup or use.

READ BEFORE UNPACKING

Your mixer stand has been tested for quality and functionality prior to shipment. Proper handling and care should be taken when the unit is moved, uncrated, and installed. Failure to abide by the following criteria may result in damage to the equipment or serious injury to those operating the product.

WARNINGS

- The equipment should only be used for the purposes and parameters discussed within this document. Any deviations above the design parameters are not recommended nor covered under our factory warranty. Contact MXD Process prior to using the equipment for any applications outside of this scope.
- Improperly tightened hardware can damage components and/or system components and can result in reduced operational life. Check all hardware to ensure nothing loosened up during shipping. Refer to Appendix 1 for fastener torque values.
- When working with equipment with high voltage or rotating components, the potential to inflict severe or even fatal injury is present. Only qualified personnel should attempt installation, operation, or maintenance on the equipment. Never service without first ensuring that all power to the equipment is de-energized and the equipment has been properly locked-out. Any installer should be aware of relevant electrical codes and safety standards.
- MXD Process is not responsible for damage or injury due to inadequate structure mounting or improper use of its equipment.
- Any modification or alteration made to the equipment that is not authorized by MXD Process may damage products, void product warranty, or cause serious injury.

MXD Process
4650 New Middle Road
Jeffersonville, IN 47130 USA
Office: (812) 202-4047
Serial Number:



Contents

- 1.0 Initial Inspection, Receiving, and Storage.....3
 - 1.1 Inspection and Receiving.....3
 - 1.2 Storage.....3
- 2.0 Customer Support3
 - 2.1 Contact information3
 - 2.2 Warranty.....3
 - 2.3 Return Policy.....4
- 3.0 General Information4
 - 3.1 Product Details4
 - 3.2 Options4
- 4.0 Assembly and Operation4
 - 4.1 Assembly.....4
 - 4.2 Mixer Installation.....4
 - 4.3 Mixer Wiring Installation.....5
 - 4.4 Lift Operation5
- 5.0 Maintenance.....5
 - 5.1 Lubricating6
 - 5.2 Cleaning6
 - 5.3 Hydraulic Cylinder6
- 6.0 Troubleshooting Guide.....7
- 7.0 EHS Diagrams.....8
- Appendix 1 – Fastener Torque Values..... 10

1.0 Initial Inspection, Receiving, and Storage

1.1 Inspection and Receiving

Upon receiving the equipment, inspect for accuracy and possible shipping damage. Take note of any missing components. If damage is observed or items are missing, please report this error to the shipping carrier and MXD Process immediately. Do not discard provided packaging until all items are accounted for.

1.2 Storage

When storing the equipment, choose a location where the equipment is not subjected to elements of nature, moisture, and/or excessive mechanical vibrations. If the unit was in storage for greater than a year, a visual inspection shall be performed before placing the unit into service. Exposed carbon steel surfaces should be inspected for corrosion that may have occurred during storage. Refer to maintenance section (Section 6) for corrective actions or contact MXD Process if needed. Please follow these steps to help prepare the equipment for long term storage:

- Store at ambient temperature, approximately 32°F to 104°F (0°C to 40°C) and avoid relative humidity conditions in excess of 60%
- Cover unit to prevent excessive dust build-up

2.0 Customer Support

2.1 Contact information

Have an issue? Contact us.

Name	Number	Email	Business Hours
MXD Process Technical Support	(812) 202-4047 x2	support@mxdprocess.com	8am - 5:30pm EDT
MXD Process Technical Sales	(812) 202-4047 x1	sales@mxdprocess.com	8am - 5:30pm EDT

2.2 Warranty

MXD Process is not accountable for any alteration, customization, misuse, or improper assembly of its products or components. Warranties may also be voided by unauthorized disassembly of equipment. MXD Process shall not be liable for any other damages, whether consequential, indirect, or incidental, arising from the sale or use of its products.

Products are guaranteed against defective materials and workmanship. If such defects arise, MXD Process will repair or replace these items at the convenience of the customer. For items manufactured by MXD Process, the warranty period is one year. On items not manufactured by MXD Process, the manufacturer’s warranty applies. All component parts are covered by these warranties, except for normal wear items such as belts, bearings, seals, set screws, etc.

For warranty repairs, equipment is to be returned to MXD Process at the customer’s expense with an authorized RMA number issued from MXD Process. The product(s) will be evaluated, restored to original equipment standards, then returned to the customer at the expense of MXD Process. This warranty is exclusive and is in lieu of all other warranties, whether expressed or implied.

2.3 Return Policy

All sales are final with Mixer Direct and MXD Process due to the level of complexity and customization of our industrial products.

All returns must be approved in advance by a Technical Support Lead, reference a valid Mixer Direct or MXD Process RMA number, and will be subject to a 50% restock fee.

Please contact Technical Support for all returns. When you call, please have the following available for reference:

- Unit Serial Number, Sales Order Number, or Purchase Order number
- Part number and description of the purchased product
- Reason for returning the product

3.0 General Information

3.1 Product Details

The ShearPro EHS is a portable medium duty mixer stand designed to support up to 250LB Batch Rotor Stator mixers, or other mixers that mount using the same methodology. The stand has 2 locking swivel casters in the back and two fixed wheels in front. The stand has a 59" advertised lift stroke but a maximum usable lift height of 104.5". Due to the nature of the hoist stand, the usable stroke will depend on the height mixer being used.

3.2 Options

The stand comes with a manual hydraulic lift but can be optioned with an air and manual ram for easier operation. The stand includes a cord hanger, and provisions for mounting the optional variable speed controllers for the ShearPro Batch Rotor Stators

4.0 Assembly and Operation

4.1 Assembly

For ease of shipping, the ShearPro Economy Hoist Stand will ship partially disassembled. It may be necessary to assemble the tower to the portable base and install the hoist cylinder to the stand.

- Assemble tower to base using provided (4) ½" bolts, flat washers and lock nuts (3/4" wrench size). Torque bolts (see appendix 1 for torque values)
- Install cylinder into tower, pump side forward, using provided ½" bolts and lock nuts on base and end of ram. These bolts should be tightened so the nut is fully engaged with the nylon but loose enough to allow rotational movement.

4.2 Mixer Installation

The Economy Host Stands use a hanger rod to hold the Batch Rotor Stator. The hanger rod is specific to the frame size of the mixer and is included with new Batch Rotor Stator mixers. The rod threads through the mounting hole at the end of the stand arm and the mixer hangs from the rod. See figure 4.2.0

4.3 Mixer Wiring Installation

When the optional variable speed controller is used, the mounting plate for the VFD is secured using the included hardware to the threaded inserts on the back of the tower, just above the push handle. See Figure 4.2.1. Any wiring secured to the mixer stand should use a suitable locking connector to allow removal of the mixer for service or if multiple mixers are used with one stand. Mixer wiring should be done in a manner to allow the full stroke of the lift without putting unnecessary tension on the wire/cord.

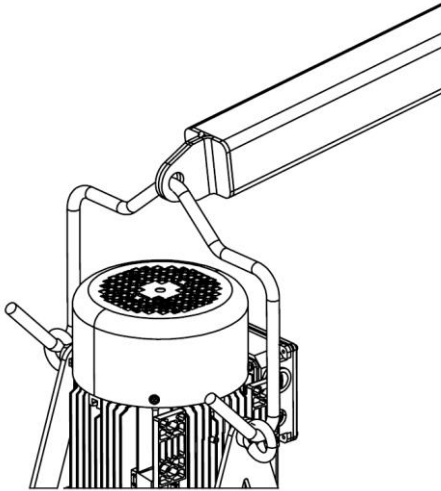

Figure 4.2.0 Hanger Rod

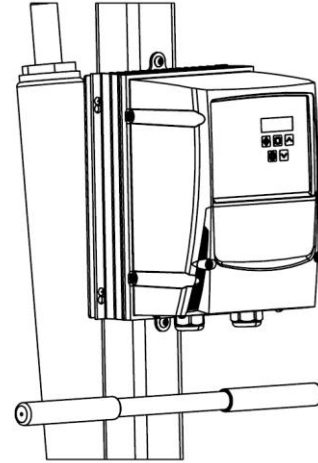

Figure 4.2.1 VFD Mount

4.4 Lift Operation

Raising the lift

- Turn release knob clockwise until it is firmly closed
- Insert handle into pump, pump handle up and down to raise the lift
 - For the optional air powered ram, an air line may be connected to the valve and the lever depressed to raise the lift instead of using the pump handle.
- Remove handle from pump and store when not in use

Lowering the lift

- Turn the release knob counterclockwise slowly to lower the lift. Lowering speed is determined by how much the knob is rotated
- Once lift is in desired position, turn release knob clockwise again until its firmly closed

5.0 Maintenance

To ensure the life and longevity of the equipment, regular inspection and maintenance is suggested. The equipment should be inspected at regular intervals as part of your standard maintenance program. How often various components should be inspected and serviced will depend on operating environment and process

conditions. When performing maintenance on any moving or electrical equipment, de-energize all power and lock-out the equipment before beginning. Remove mixer (if installed) before servicing.

5.1 Lubricating

All pivot points on your ShearPro Economy Hoist stand use lubrication free bearings designed for a long worry-free service life without additional lubrication.

5.2 Cleaning

It is important to ensure a long service life to keep the equipment clean. Using a mild cleaning solution to wipe down the stand and cylinder and keep dirt, grime and contaminants out of the cylinder and pivot points on the stand.

5.3 Hydraulic Cylinder

To purge any air from the cylinder

- Turn release knob counterclockwise one full turn
- Rapidly pump the handle 6-8 times, leave the handle in the down position
- With a flat blade screwdriver, push the oil fill plug slightly to the side to purge any trapped air (use caution to not damage the plug)
- Turn the release knob clockwise to the closed position

To add oil to the cylinder

- Turn the release knob counterclockwise to lower the lift to the lowest position
- Remove the oil plug
- Fill oil case until level is just below the hole
- Replace oil plug
- Perform the air purge procedure

Only anti-foaming hydraulic jack oil should be used to prevent damage

6.0 Troubleshooting Guide

PROBLEM	POSSIBLE CAUSE	SUGGESTED SOLUTION
Stand will not raise	Release knob is not completely closed	Turn knob clockwise until closed
	Air is trapped in cylinder	Perform air purge procedure
	Low oil level	Add oil
	Pump is damaged	Replace cylinder
Stand will not stay in position	Release knob is not completely closed	Turn knob clockwise until closed
	Low oil level	Add oil
	Leaking cylinder seals	Replace cylinder
Stand will not lower	Overfull oil reservoir	Drain extra oil
	Stand is bound	Inspect for damage
	Foreign object obstruction	Clear lowering path
Stand will not raise fully	Low oil level	Add oil
Stand hard to move	Flat spots on caster(s)	Inspect and replace caster(s)
	Worn bearing(s) on caster(s)	
	Damaged caster(s)	
	Foreign object obstruction	Clear pathway

7.0 EHS Diagrams

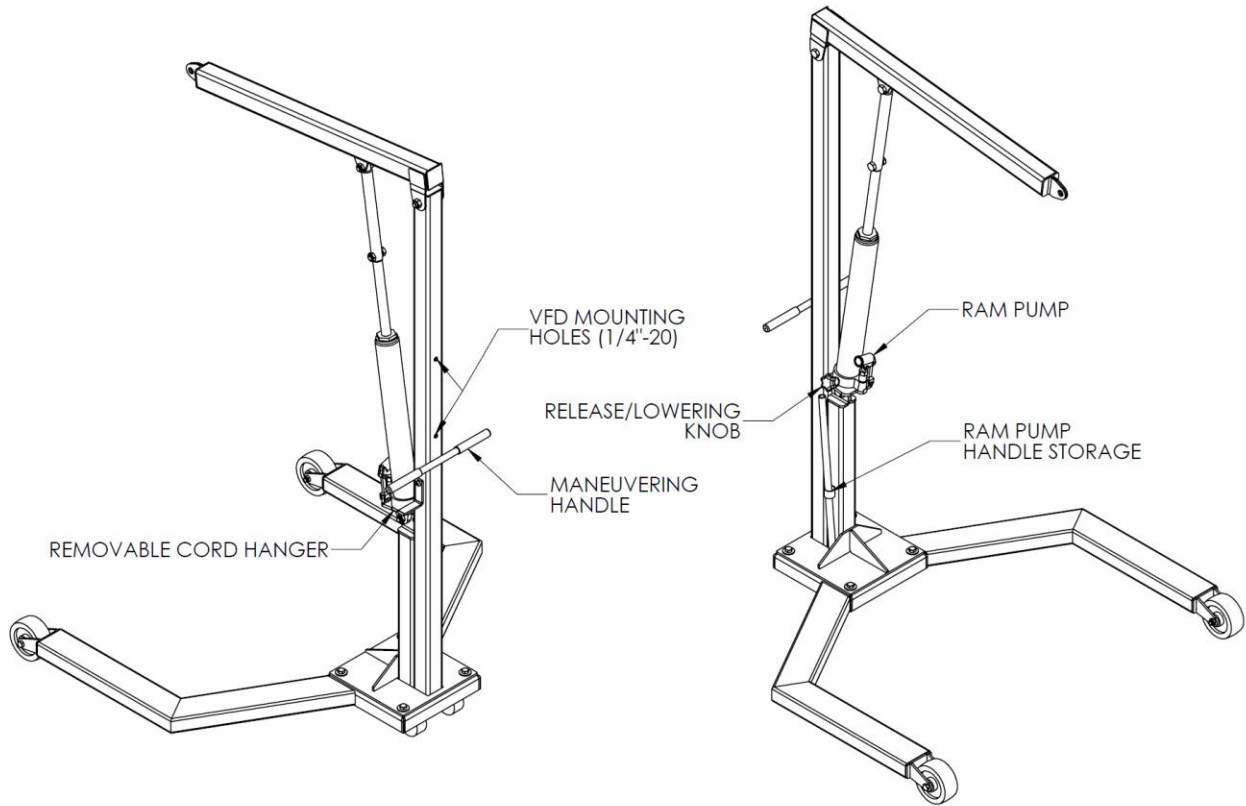

Figure 8.0.0 – EHS Stand features

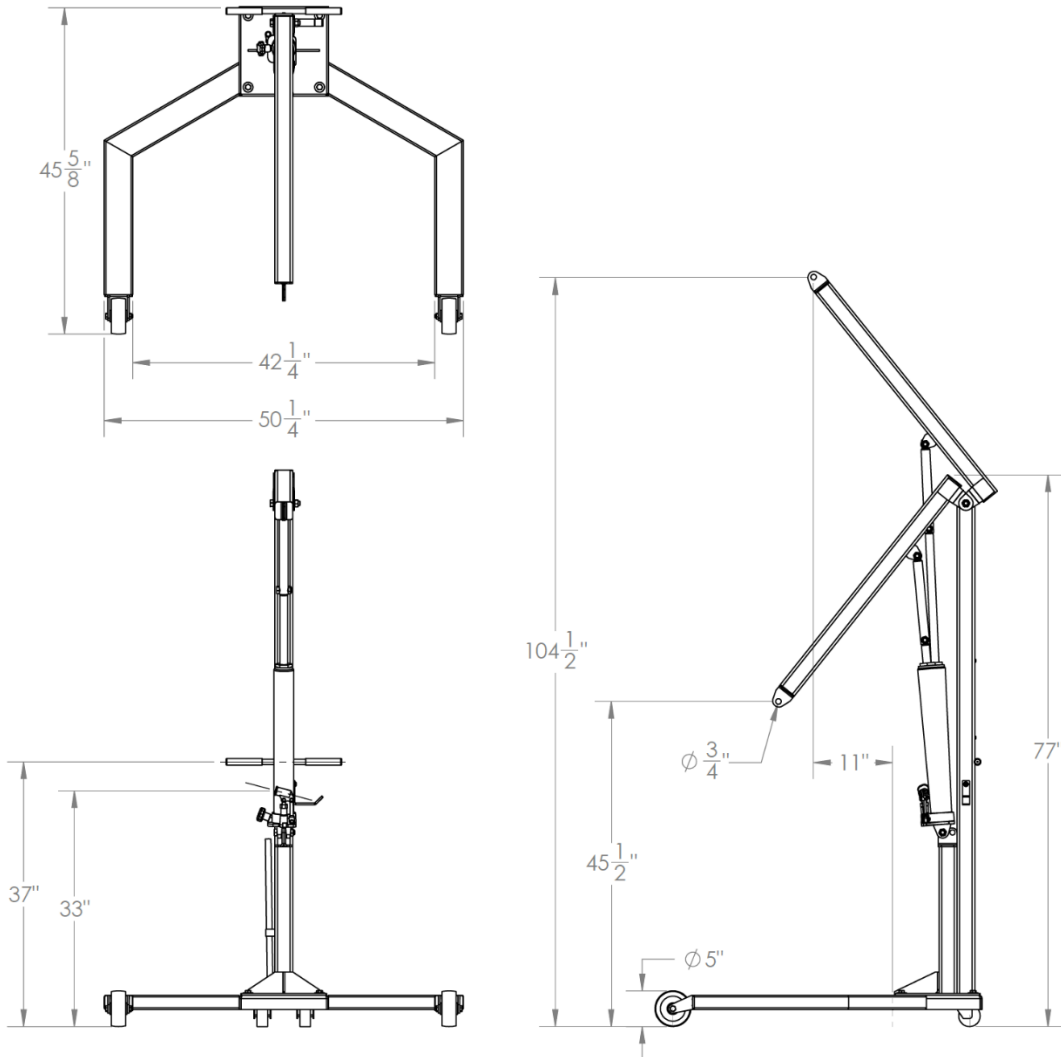

Figure 8.0.1– EHS Dimensions

Appendix 1 – Fastener Torque Values

Table A4.1 – Screw & Bolt Torque Values					
		SAE J429	SAE J429	ASTM A574	ASTM F593
	Nominal Size	Grade 5	Grade 8	SHCS	304/316 SS
INCH LBS	#10	31	44	50	20
	#12	49	70	79	29
	1/4	76	107	120	62
	5/16	156	221	249	128
	3/8	23	32	36	19
FOOT LBS	7/16	36	52	58	30
	1/2	57	80	90	46
	5/8	113	159	179	92
	3/4	200	283	318	113
	7/8	322	455	512	182
	1	483	682	767	273
	1-1/8	684	966	1086	346
	1-1/4	965	1363	1533	545

All values are for coarse thread lubricated fasteners

Table A4.2 - Set Screw Torque Values				
	Nominal Size	Alloy Steel	Stainless	Hex Size
INCH LBS	#8	20	13	5/64
	#10	36	23	3/32
	1/4	87	57	1/8
	5/16	165	107	5/32
FOOT LBS	3/8	24	16	3/16
	7/16	35	23	7/32
	1/2	52	34	1/4
	9/16	52	34	1/4
	5/8	110	72	5/16
	3/4	200	130	3/8
	7/8	300	195	1/2
	1	417	271	9/16

All values are for coarse thread lubricated fasteners