

Bung Mount Mixer Manual

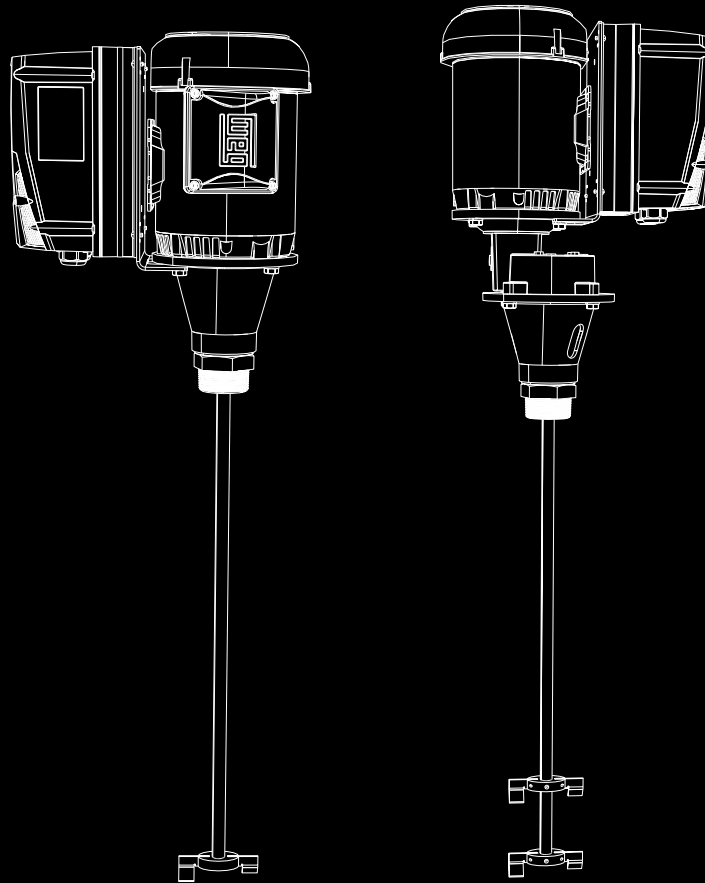

Installation, Operation, & Maintenance for Bung Mount Mixer



Every Process We Touch, We Improve

Table of Contents

Safety	3
General Safety	3
Maintenance Safety.....	3
Electric Motor Safety	4
Pneumatic Motor Safety.....	4
General Information	5
Introduction	5
Inspection and Receiving.....	5
Customer Support.....	5
Warranty	6
Return Policy	6
Assembly	7
Pre-Assembly Checklist.....	7
Motor Installation.....	7
Variable-Frequency Drive (VFD) Installation (if applicable).....	11
Shaft Installation.....	13
Impeller Installation.....	15
Wiring/Electrical.....	16
Startup and Operation	17
Rotation Direction	17
General Operation Principles	17
Startup and Operation Checklist.....	17
Operation	17
Maintenance	19
Gearbox Lubrication	19
Shaft Runout Check.....	20
Seal and Bearing Replacement	21
Troubleshooting Guide	23
Diagrams and Spare Parts	24
Direct Drive	24
Gearbox Drive	26
Information Tables	28
Torque Specifications	28

General Safety

Safety is the most important element of the operation and maintenance of your new equipment. Knowledge of the procedure to be performed and safe work habits are essential to preventing death, personal injury, or property damage. Use the following statements as a common-sense guide to proper work and tool-use habits.

Prepare for the Job

Preparation is essential to complete a procedure in a safe and efficient manner.

- Wear proper clothing. Loose or baggy clothing could become tangled in moving parts.
- Use eye/face protection. Always use proper eye/face protection to protect your eyes from flying debris or chemical splatters.
- Wear protective footwear. Wear safety shoes (steel-toe) to protect your feet from falling objects.
- Use gloves when handling parts. Parts may have sharp edges or may be hot.
- Remove jewelry prior to servicing electrical systems.
- Prepare proper tools and equipment. Always use the correct tool for the job. Improper or homemade tools can cause injury or machine damage.
- Prepare needed parts and materials. Gather the needed parts and materials before beginning the procedure.
- Many components can get hot during operation. Be sure to allow enough time for components to cool before beginning service.
- Prepare proper work-space lighting. A well-lit work area can make the job easier.
- Follow procedures and safety warnings. Service procedures are written to be as safe and efficient as possible. Never take shortcuts.
- Be prepared for emergencies. Accidents can happen, even under the best conditions. Fire extinguishers and first aid kits should be well maintained and easily accessible.

Safety Notices

Please read this entire manual before attempting to operate or service equipment. Failure to follow these instructions could result in serious bodily injury or death.

Throughout this manual, the following key safety words will be used to alert the reader of potential hazards. Become familiar with these words and their meaning. Take all precautions to avoid the hazards described.

DANGER

Indicates an imminently hazardous situation which, if not avoided, will result in death or serious bodily injury.

WARNING

Indicates a potentially hazardous situation which, if not avoided, may result in serious or moderate bodily injury.

CAUTION

Indicates a potentially hazardous situation which, if not avoided, may result in minor or moderate bodily injury.

NOTICE

Indicates a situation which, if not followed, may involve deterioration or damage to equipment.

Maintenance Safety

WARNING

Before doing any service or maintenance on this machine, Follow all safety procedures. This should include:

- Disconnect the electrical power supply.
- Relieve any pressure from the pneumatic system.
- Mechanically secure any part of the machine that may shift while doing maintenance.

Electric Motor Safety

WARNING

ELECTRICAL SHOCK!

De-energize unit before servicing. Failure to follow this instruction may result in serious injury.

WARNING

AVOID POSSIBLE INJURY, ROTATING PARTS!

Please make sure to keep your hands, hair and loose clothing away from rotating parts to avoid any injuries. Failure to do so, may result in serious injury.

CAUTION

HOT PARTS DO NOT TOUCH!

During and after operation, motor and auxiliary components can become hot. To avoid severe burns, do not touch motor and component parts while in use or immediately after stopping.

NOTICE

All Electric Motors should be in accordance with National Electrical Code, NEMA along with local codes. All grounding should be in accordance with National Electrical Code (NEC) Article 430.

ATTENTION: Under no circumstances should anyone other than qualified professionals be responsible for electrical connections and repairs. The potential dangers of electricity are far too great to be taken lightly. Therefore, it is imperative that safety is prioritized above all else and that only individuals with the necessary qualifications and expertise are entrusted with electrical work.

Variable-Frequency Drive (VFD) Safety

WARNING

ELECTRICAL SHOCK!

This device will store a charge for up to 3 minutes after removing the main voltage from the unit. Always discharge or allow ample time before servicing. Failure to follow this instruction may result in serious injury.

Pneumatic Motor Safety

When utilizing pneumatic motors, it is imperative to exercise caution and implement necessary safety measures, despite their lower risk profile in comparison to electric motors in relation to overheating or explosion.

DANGER

AVOID POSSIBLE EXPLOSION

Never operate this unit with explosive gases or allow corrosive gases into the motor. The air motor is designed for air only. Filter out all water vapor, oil-based contaminants, or any other liquids before use. Failure to follow this instruction may result in serious injury or death.

WARNING

AVOID POSSIBLE INJURY, ROTATING PARTS!

Please make sure to keep your hands, hair, jewelry and loose clothing away from rotating parts to avoid any injuries. Disconnect the motor from the air line before any adjustment operation. If you fail to do so, it may result in serious injury.

NOTICE

Use only the approved lubrication for your pneumatic motor to ensure optimal function. Failure to do so may result in malfunction or complete failure of the motor.



Introduction

Congratulations on your purchase of the MXD Process Bung Mount Mixer! This manual provides comprehensive guidance on the installation, set-up, operation, maintenance, and repair of your bung mount mixer, as well as general information. We recommend reading this operation and maintenance manual in its entirety before setting up or using the mixer to ensure safe and efficient operation. We thank you for choosing our product and look forward to providing you with any assistance you may need.

READ BEFORE UNPACKING

NOTICE

Please note that your MXD Process bung mixer has undergone rigorous quality testing before shipment. It is important to exercise proper care and handling when moving, uncrating, and securing the mixer components to their mounting surface. Failure to adhere to the guidelines below may result in damage to the equipment or serious injury to those operating the products.

Inspection and Receiving

Upon receipt of the equipment, it is imperative to conduct a thorough inspection to ensure accuracy and identify possible shipping damage. It is highly recommended to take note of any missing components and promptly report any observed damage or missing items to both the shipping carrier and MXD Process. It is advisable to refrain from discarding the packaging provided until all components have been accounted for, and product has been confirmed to be free from transit damage. For a detailed list of components, please refer to the Spare Parts Section of the manual.

Storage

When it comes to storing mixing equipment, it is important to select a location that is free from exposure to elements of nature, moisture, and excessive mechanical vibrations. This is especially important as electrical components are not designed to withstand moisture. In the event that the mixer has been in storage for more than a year, it is recommended that the gear lubricant be checked prior to the mixer being put into service. Additionally, exposed carbon steel surfaces, such as the gearbox's hollow bore, should be inspected for any corrosion that may have occurred during storage. For corrective actions, please refer to the maintenance section or contact MXD Process if further assistance is required. To prepare the equipment for long-term storage, please follow these steps:

- Check mixer functionality before storing.
- For optimal storage of the mixing equipment, keep it at an ambient temperature between 32°–104°F (-0°–40°C) and avoid relative humidity over 60%.

- To ensure proper storage of the gearbox, it is recommended that it be kept in its actual mounting position, with a horizontal orientation and the mount parts facing downward.
- It is recommended to cover the unit to prevent excessive dust buildup, which can have a detrimental effect on the equipment's overall performance.
- To prevent corrosion and ensure optimal performance, it is recommended to apply a protective lubricant coating to all unpainted carbon steel surfaces, including the gearbox hollow shafts. This step is crucial in maintaining the integrity of the equipment and extending its lifespan. Additionally, regular inspections should be carried out to check for any signs of corrosion.
- To prevent any potential corrosion inside the unit, it is recommended to overfill the gearbox with oil. By taking this step, it is possible to ensure that the equipment is properly lubricated and protected against potential damage
- To ensure that the oil is properly distributed to internal surfaces and to prevent brinelling of the bearing races, it is recommended to rotate the gearbox once a month, approximately 10–20 revolutions in both directions. By following this approach, it is possible to maintain optimal equipment functionality and extend its lifespan.

Customer Support

If you encounter any problems or have any questions, feel free to contact us. We are here to help in any way we can.

Contact Information

- MXD Process Technical Support
(812) 202-4047 x2
support@mxdprocess.com
8am - 5pm EDT
- MXD Process Technical Sales
(812) 202-4047 x1
sales@mxdprocess.com
8am - 5pm EDT

Warranty

MXD Process prides itself on providing high-quality products to our customers. To ensure you get the most out of our equipment, we kindly remind you that any alteration, customization, misuse, or improper assembly of our mixer or mixer components is not our responsibility. Such actions may void your warranty and can result in serious harm or damage. We encourage you to carefully follow the instructions provided to ensure safe and proper use of our equipment.

Our products are crafted with the highest standards of materials and workmanship, and we stand behind them with confidence. In the unlikely event that you encounter defects, we offer a one-year warranty on items we manufacture and the manufacturer's warranty on other items we do not manufacture. All component parts are covered by these warranties, except for normal wear items like belts, bearings, set screws, etc.

To initiate a warranty repair, please contact us for a Return Material Authorization (RMA) number. Returns must be made within the specified window and packaged comparably to their initial shipment. We recommend using the original packaging, if reusable.

At MXD Process, we value your business and are committed to providing only the best products and services. Our warranty is the only one we offer and supersedes all other warranties, whether expressed or implied, so you can have peace of mind knowing that you are covered.

Return Policy

All returns require approval from our Technical Support Team and are subject to a re-stocking fee. In order to return a product, you need to obtain a Return Material Authorization (RMA) number. We will not process any return or credit without an authorized RMA number. Please make sure to package your return in a comparable manner to how it was initially shipped. If the original packaging is reusable, we recommend using it for the return. Please note that products must be returned within 10 business days from the date of issuance of the RMA.

If you need to return any of our products, please do not hesitate to reach out to our Technical Support team at (812) 202-4047 x2. Our team is available to assist you and make the process as easy as possible. To help us expedite your request, kindly have the following information ready when you call:

- Mixer Serial Number (located near the motor tag), Sales Order Number, or Purchase Order Number
- Part number and description of the product you purchased
- Reason for returning the product

We appreciate your business and are committed to ensuring your satisfaction.



Pre-Assembly Checklist

- Manual has been read in its entirety
- Mixer removed from packaging and inspected for damage or missing components
- Mounting hardware is prepared, if applicable.
- Gasketing is prepared, if applicable
- Tools such as a calibrated torque wrench, sockets, ratchets, Allen keys (hex keys), and anti-seize are readily available
- Professionals, such as riggers, are on-site ready to move the equipment
- Qualified electricians are informed of the electrical requirements and prepared to wire the necessary equipment
- Installation site is prepped, cleaned, and all relevant personnel are informed

Motor Installation

Depending on the specific requirements of your application, the mixer in question may be powered either by electrical or pneumatic means, and may be configured with either a gearbox or direct drive mechanism. In certain instances, it may also be equipped with an optional Variable Frequency Drive (VFD) Speed Controller that enables the operator to gradually adjust the RPM to suit the mixing process.

Electrical Motor

Determine whether your bung mounted mixer is driven by a gearbox or is a direct drive, and proceed to the appropriate instructions.

- For gearbox installation, see "Gearbox" on page 7.
- For direct drive installation, see "Direct Drive" on page 8.

Gearbox

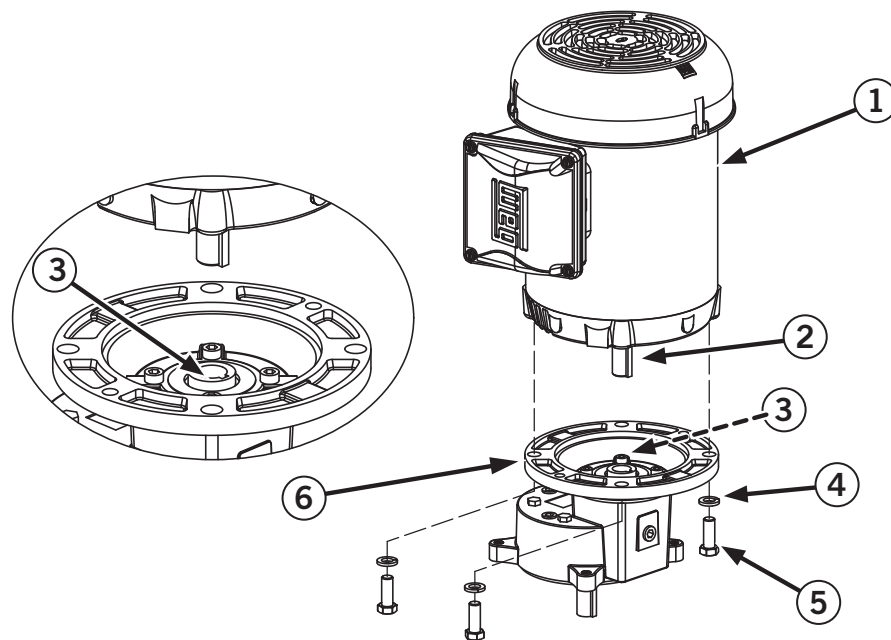

Figure 1. Motor to Gearbox

WARNING

AVOID INJURY, HEAVY COMPONENT!

It is important to utilize appropriate lifting equipment or have additional personnel present to aid in lifting heavy objects into place. Noncompliance with this directive may result in physical harm.

1. Lift the motor (1) into place and align the keyway (3) on the gearbox with the key and keyseat on the motor shaft (2).
2. Install the motor onto the gear box flange (6) and secure with four washers (4) and four cap screws (5), tighten to specification. See "Information Tables" on page 28.

NOTICE

Please note that during reassembly, it is important to ensure that the coupling has a maximum clearance of $3 \frac{7}{16}$ " with respect to the motor/gearbox mounting surface. This is particularly important when dealing with the aluminum cone versions that come with larger couplings. Failure to maintain this clearance can lead to issues with the cone hardware, even if the coupling is just centered on the shaft. See Figure 2.

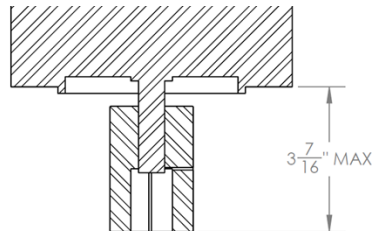

Figure 2. Clearance

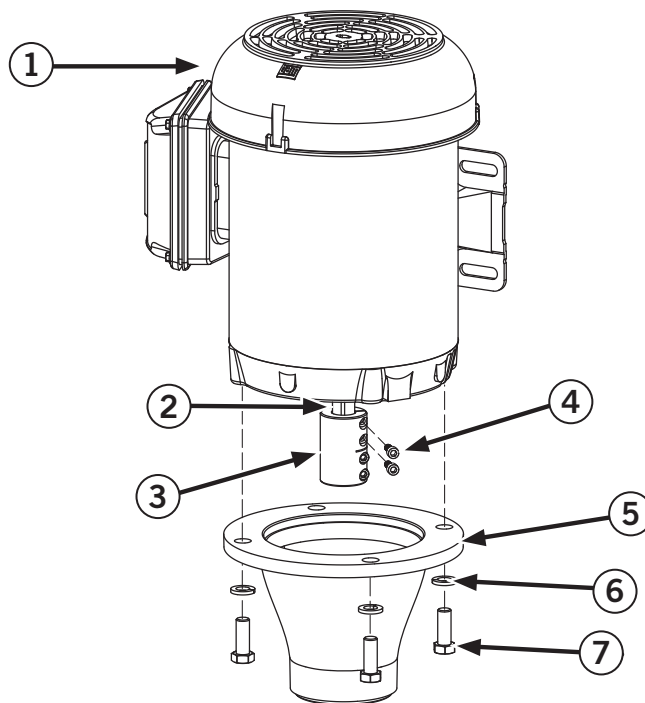

Figure 3. Electrical Motor Direct Drive

WARNING

AVOID INJURY, HEAVY COMPONENT!

It is important to utilize appropriate lifting equipment or have additional personnel present to aid in lifting heavy objects into place. Noncompliance with this directive may result in physical harm.

1. Attach the shaft coupler (3) to the motor shaft (2).
2. Install the two socket head screws (4) securing the shaft coupler to the motor, and tighten to specification. See "Information Tables" on page 28.
3. Lift the motor (1), and align the holes from the motor to the corresponding holes on the direct drive cone (5).
4. Secure with four washers (6) and four cap screws (7), tighten to specification. See "Information Tables" on page 28.



Pneumatic Motor

Determine whether your bung mounted mixer is driven by a gearbox or is a direct drive, and proceed to the appropriate instructions.

- For gearbox installation, see "Gearbox" on page 9.
- For direct drive installation, see "Direct Drive" on page 10.

Gearbox

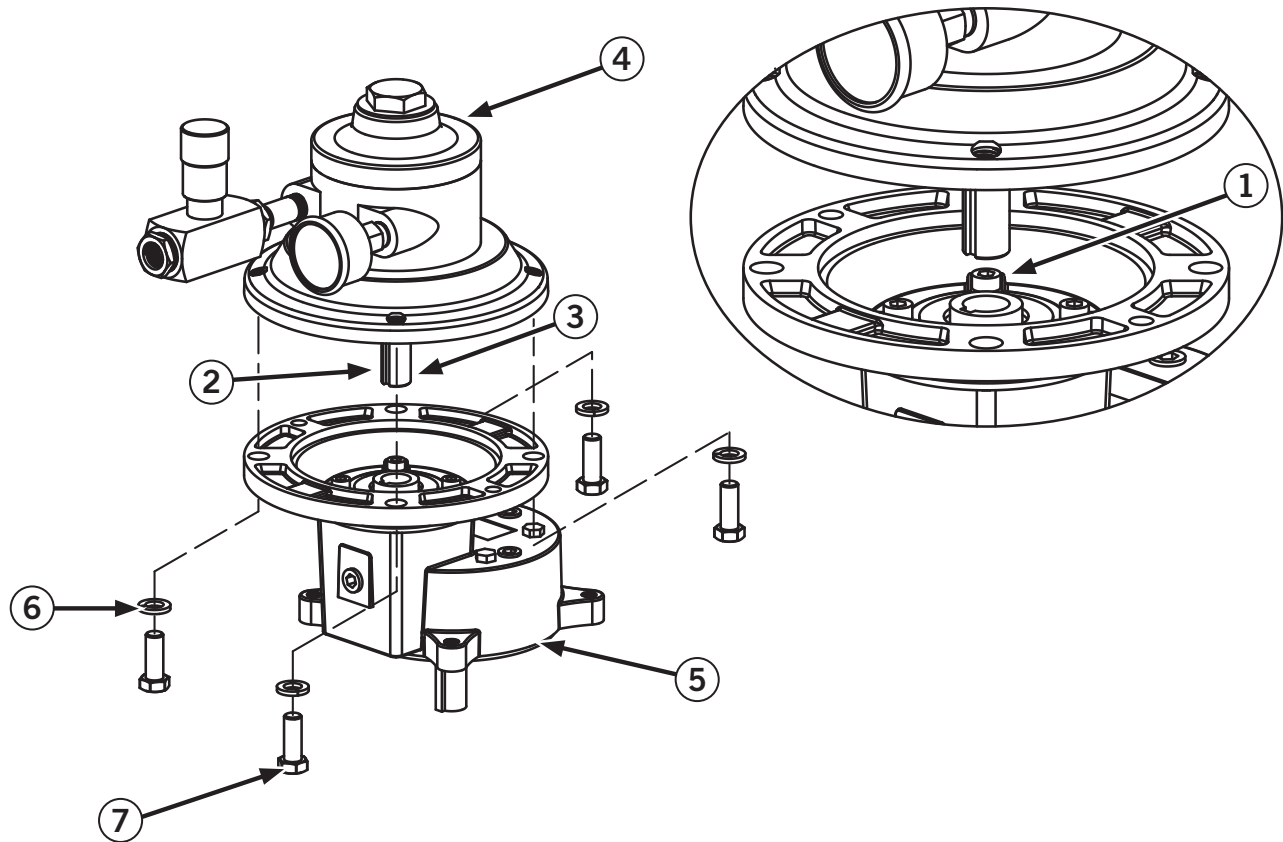

Figure 4. Pneumatic Motor to Gearbox

1. Install the key (2) into the keyseat on the motor shaft (3).
2. Lift the pneumatic motor (4) into place and align the keyway (1) on the gearbox with the key and keyseat on the motor shaft.
3. Install the pneumatic motor onto the gearbox flange (5) and secure with four washers (6) and four cap screws (7). Tighten cap screws to specification. See "Information Tables" on page 28.

NOTICE

Please note that during reassembly, it is important to ensure that the coupling has a maximum clearance of $3 \frac{7}{16}$ " with respect to the motor/gearbox mounting surface. This is particularly important when dealing with the aluminum cone versions that come with larger couplings. Failure to maintain this clearance can lead to issues with the cone hardware, even if the coupling is just centered on the shaft. See Figure 5.

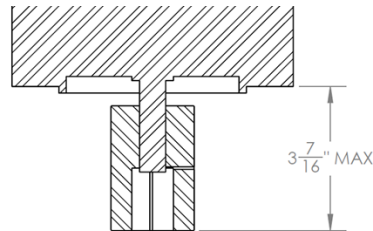

Figure 5. Clearance

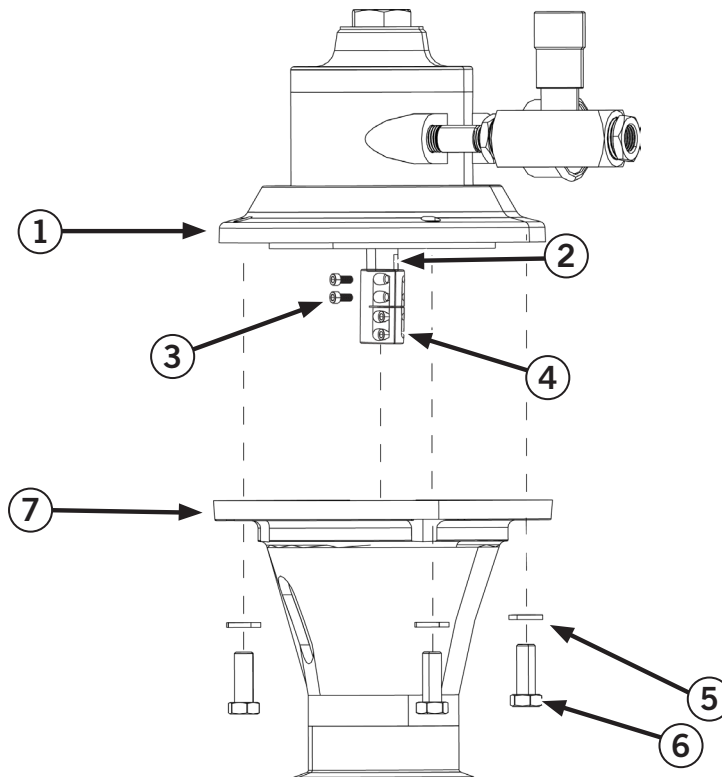

Figure 6. Pneumatic Motor Direct Drive

1. Attach the shaft coupler (4) to the motor shaft (2).
2. Install the two socket head screws (3) securing the shaft coupler to the pneumatic motor (1) and tighten to specification. See "Information Tables" on page 28.
3. Lift the pneumatic motor (1), and align the holes from the pneumatic motor to the corresponding holes on the direct drive cone (7).
4. Secure with four washers (5) and four cap screws (6), tighten to specification. See "Information Tables" on page 28.

Variable-Frequency Drive (VFD) Installation (if applicable)

The optional Variable Frequency Drive (VFD) speed controller for the bung mounted mixers allows the operator to adjust the RPM incrementally to suit the mixing application.

Gearbox

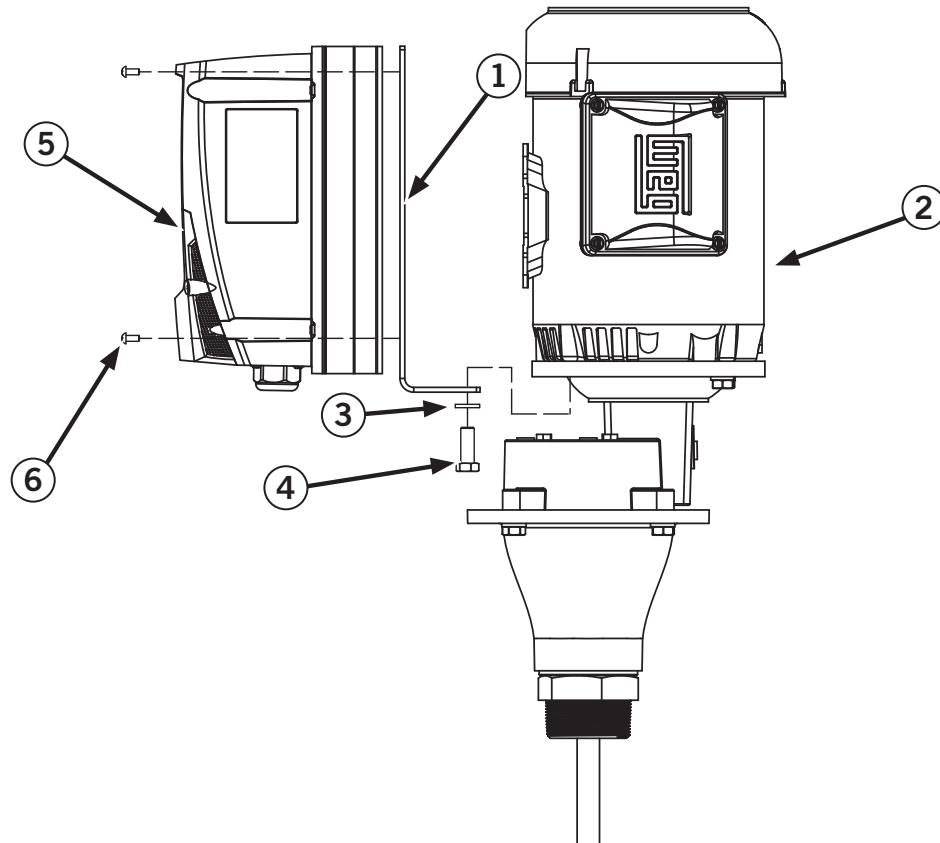

Figure 7. VFD to Gearbox

NOTE: The Variable Frequency Drive (VFD) mounting plate utilizes two cap screws and washers that secure the motor to the gearbox.

1. Align the Variable Frequency Drive (VFD) mounting plate (1) with the corresponding holes on the motor (2),
2. Secure the VFD mounting plate and motor with two washers (3) and two cap screws (4). Tighten cap screws to specifications. See "Information Tables" on page 28.
3. Install the VFD Speed Controller (5) to the VFD mounting plate, and secure with four screws (6).
4. For electrical connections, see "Wiring/Electrical" on page 16.

Direct Drive

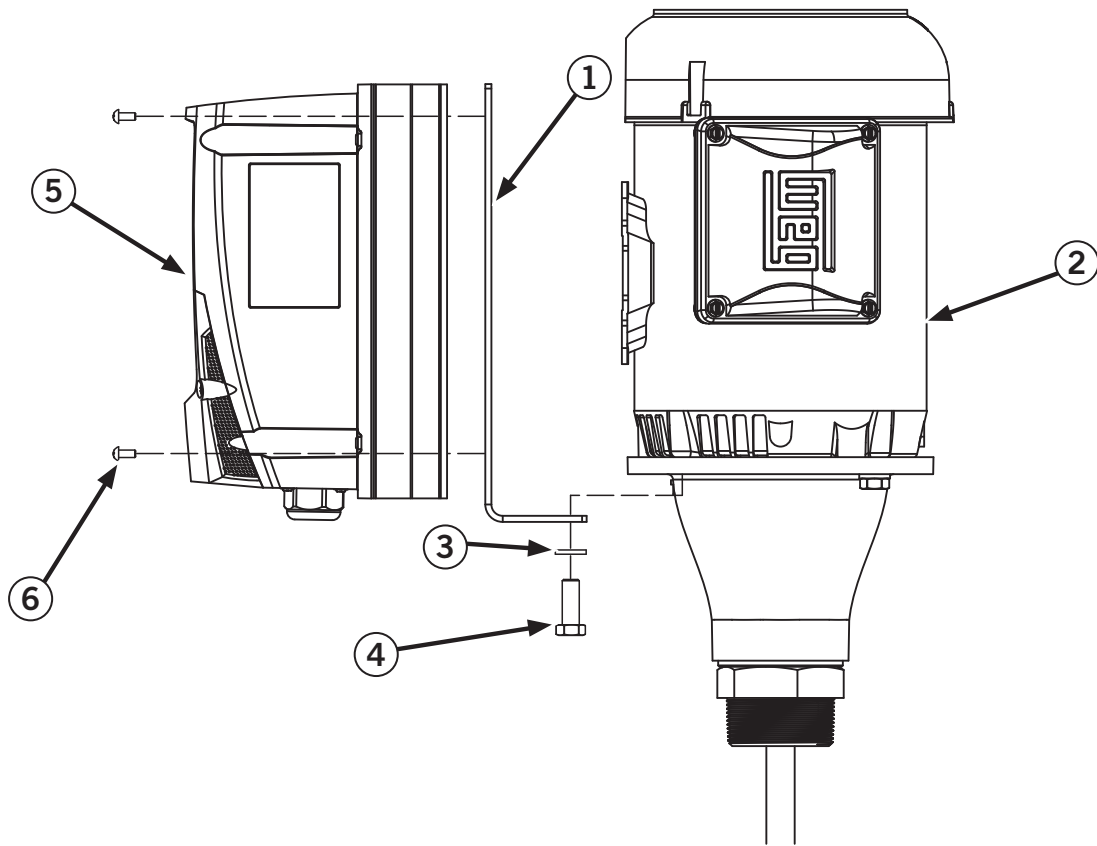

Figure 8. VFD to Direct Drive

NOTE: The Variable Frequency Drive (VFD) mounting plate utilizes two cap screws and washers that secure the motor to the direct drive cone.

1. Align the Variable Frequency Drive (VFD) mounting plate (1) with the corresponding holes on the motor (2).
2. Secure the VFD mounting plate and motor with two washers (3) and two cap screws (4). Tighten cap screws to specifications. See "Information Tables" on page 28.
3. Install the VFD Speed Controller (5) to the VFD mounting plate, and secure with four screws (6).
4. For electrical connections, see "Wiring/Electrical" on page 16.

Shaft Installation

Gearbox

The gearboxes require a shaft coupler located inside the gearbox cone. The shaft coupler is used on all the standard gear drive bung bracket mixers, and should be pre-installed on the gear shaft.

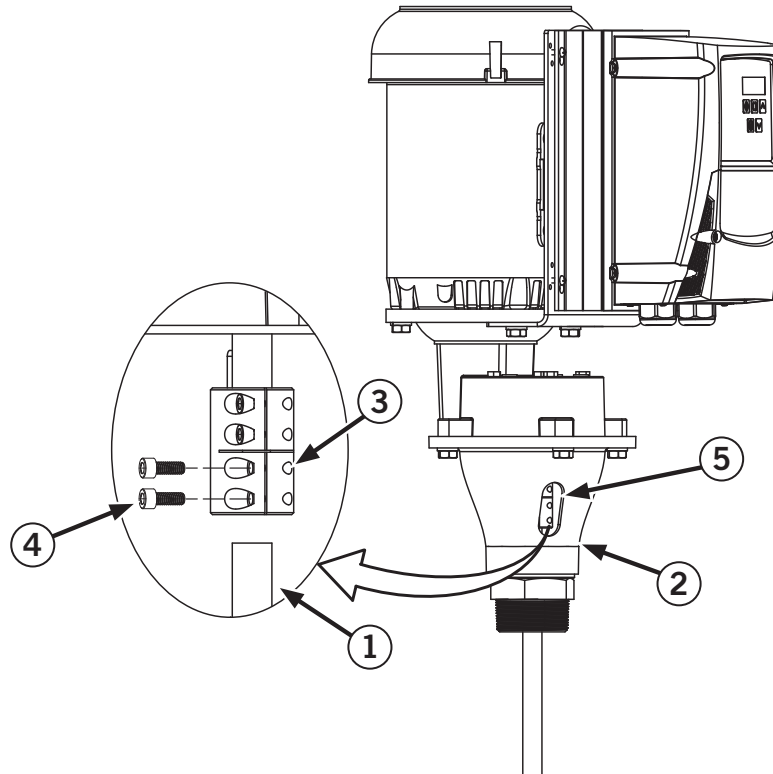

Figure 9. Shaft Installation.

1. Install the shaft (1) through the bottom of the gearbox cone (2).
2. Insert the shaft into the shaft coupler (3), and install two socket head cap screws (4).
3. Tighten socket head cap screws through the gearbox cone window (5) to specifications. See "Information Tables" on page 28.

Direct Drive

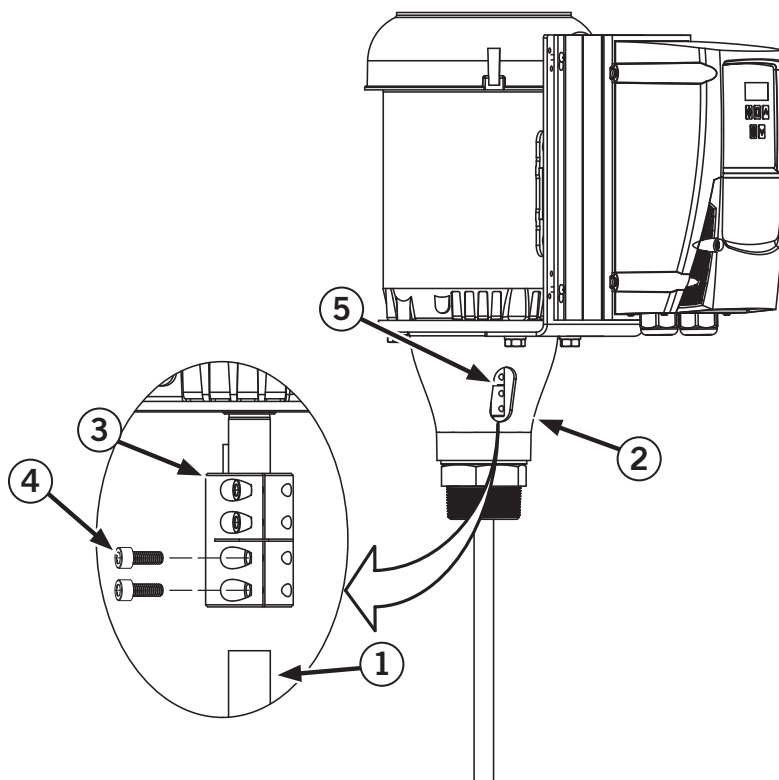

Figure 10. Direct Drive Shaft Assemble

1. Install the shaft (1) through the bottom of the direct drive cone (2).
2. Insert the shaft into the shaft coupler (3), and install two socket head cap screws (4).
3. Tighten socket head cap screws through the direct drive cone window (5) to specifications. See "Information Tables" on page 28.

Impeller Installation

Folding Impeller (FLP)

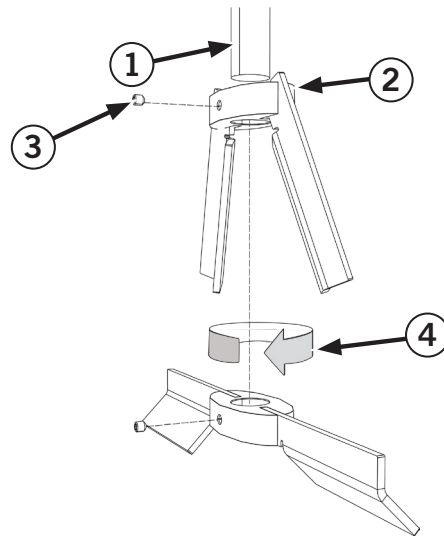

Figure 11. Folding Impeller

1. Install the FLP (2) into the shaft (1) noting the specific orientation, see rotation (4) in Figure 11. Folding Impeller.
2. Secure with a set screw (3) and tighten to specification.

Wiring/Electrical

⚠ WARNING

ELECTRICAL SHOCK HAZARD!
 When working with high-voltage equipment, always de-energize unit before servicing. Failure to follow this instruction may result in serious injury.

⚠ WARNING

AVOID POSSIBLE INJURY, ROTATING PARTS!
 Please make sure to keep your hands, hair, jewelry and loose clothing away from rotating parts to avoid any injuries. Disconnect the motor from the air line before any adjustment operation. If you fail to do so, it may result in serious injury.

NOTICE

It is important to note that all electrical work must be completed by a licensed electrician. We strongly advise against performing such work without the appropriate qualifications and training, as it can pose a serious risk to both the individuals involved and the property being serviced. Therefore, it is recommended that qualified electricians be contacted and utilized for any electrical work required.

NOTICE

All electric motors should be in accordance with National Electrical Code (NEC) NEMA along with local codes. All grounding should be in accordance with National Electrical Code (NEC) Article 430.

It is important for installers to be aware of all the electrical codes and safety standards. To make maintenance and servicing easier, MXD Process suggests having an electrical disconnect switch or circuit breaker for each mixer unit to de-energize the power. All motors and VFDs must be wired according to the provided wiring diagrams for ease of de-energizing electrical power during maintenance and servicing.

It is imperative to verify the appropriate shaft rotation after wiring. When viewed from above, the impeller’s rotation direction should be clockwise. Should a counterclockwise rotation be observed, it is critical to adhere to all relevant electrical codes and safety standards, as well as to de-energize power and secure the unit before adjusting the wiring. To reverse the unit’s operation, for 3-phase motors, including all mixers with VFDs, swap any two line wires (L1, L2, or L3) according to the wiring diagram on the motor. For 1-phase motors, refer to the motor nameplate wiring diagram to determine which wires should be swapped (usually T5 and T8).

NOTE: Please refer to the wiring diagram attached to the motor for proper connection and reversing instructions.

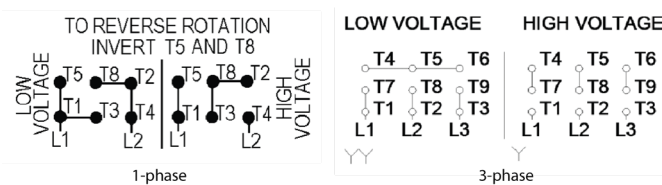

Figure 12. Typical NEMA Wiring Diagrams

(Optional) Variable Frequency Drive (VFD) Wiring

VFDs are usually shipped without wiring. When wiring, it is important to follow the VFD speed controller manual included in the package or refer to the wiring instructions provided below. For your convenience, the speed controllers are unboxed and pre-programmed by MXD Process. Please contact MXD Process if you need a digital copy of the VFD Manual or refer to the Invertek website. (www.invertekdrives.com)



Startup and Operation

Rotation Direction

When looking down into the container, the mixer rotates in a clockwise direction. If the rotation is reversed, it may result in overloading and ineffective mixing of the contents. The impellers used in the mixer are selected according to the horsepower of the mixer. To avoid bending of the impeller blades, it is recommended to operate the mixer in the reverse direction only intermittently.

General Operation Principles

It is important to note that the mixer should not be operated for an extended period of time when the tank is empty, when the liquid level is at or near the bottom of an impeller, or when impellers are splashing. For proper mixing and stabilizing of the mixing shaft, MXD recommends maintaining at least one impeller diameter of liquid level above the impeller. Additionally, it is crucial to ensure that the mixer is securely fastened to a suitable mounting location before attempting to operate it. Finally, it is recommended to only operate the mixer at speeds outlined in the document or pre-programmed in the optional Variable Frequency Drive (VFD).

These mixers are also not designed for outdoor use and are not rated for extreme temperatures, whether hot or cold. It is recommended to maintain normal operating temperatures between 14°–104°F (-10°–40°C) to ensure optimal performance.

To ensure the mixer's longevity and efficiency, it is essential to keep the motors free of foreign debris, including but not limited to oil, dust, dirt, water, or chemicals. Protect the air intakes and outputs from any foreign material that may cause blockages or damage the equipment.

Furthermore, it is important to follow the manufacturer's recommendations for maintenance and cleaning to ensure that the equipment is in good working condition. Regular inspections and maintenance will help prevent equipment failure, reduce downtime, and extend the life of the equipment.

Startup and Operation Checklist

- Please ensure that the manual has been read and the instructions have been followed.
- The shaft rotation must be clockwise when looking down at the mixer.
- Do not handle the mixer by the shaft. Lifting and handling the mixer by the shaft will cause damage.
- The equipment should be kept in an appropriate environment.
- The impeller(s) should be installed correctly.
- Make sure that the mounting/impeller bolts are tightened to the proper torque.
- Check the straightness of the shaft by slowly rotating by hand before operation in fluid.
- The mixer support should be sufficient for the mixer application.
- Use the proper type and amount of lubricant.
- Check if the wiring is correctly installed, grounded, and insulated.
- Fluid level must be a minimum of the equivalent to one diameter above the impeller for proper mixing.

Operation

NOTICE

It is important to remember that a mixer should never be operated without an impeller. Similarly, an impeller should never be operated outside of a container. Following these guidelines will help ensure safe and proper use of the equipment.

Electric

After successfully wiring the electric motor, it is imperative to check the rotation to ensure that the mixer shaft is moving in a clockwise direction. To do this, you can simply look down into the container and observe the direction of the mixer shaft. If it is moving in a counterclockwise direction, you may need to adjust the wiring to rectify the issue. Checking the rotation of the mixer shaft is a crucial step to ensure that the mixer operates efficiently and effectively.

Pneumatic

Before connecting the air supply to the mixer, it is crucial to ensure that the air valve is closed. Next, take a moment to check the rotation of the mixer shaft. This can be done by looking down into the container and observing whether the shaft is rotating clockwise. By following these steps, you can ensure that the mixer is operating safely and effectively.

When you place the mixer inside the container, it becomes safe to operate. It is important to start and stop the mixer at the slowest speed to prevent any potential hazards or accidents. By doing so, you can ensure a smooth and efficient mixing process without any unwanted mishaps.



Startup and Operation

Air Motors

WARNING

The air stream from an air motor may contain solid or liquid material that can result in eye or skin damage. DO NOT USE combustible gases to drive your air motor. Wear hearing protection. Sound levels may exceed 85db.

Air motors should be installed with air lines equal to or greater than the diameter of the inlet port. In order to provide proper lubrication and air dehydration you should have an in-line moisture trap and filter/lubricator (not included) installed ahead of the motor (see photos below). To reverse shaft rotation of air motors, swap air inlet valve and muffler fittings.

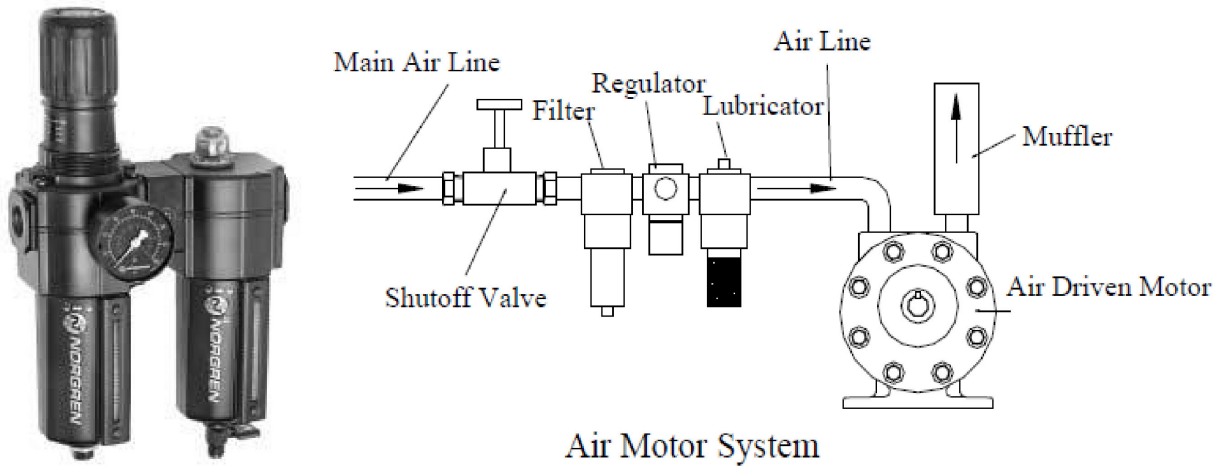

Figure 13. In-line moisture trap and filter/lubricator

Excessive moisture can cause rust to appear inside the motor and possibly cause the muffler to ice up. The lubricator should be adjusted to feed one drop of oil per minute for every 25 CFM of air flow through the motor. Use an SAE #10 air tool oil for optimal performance.

CAUTION

Allowing excessive moisture and/or foreign particles into the air motor will void the warranty.

All air motor-powered mixers manufactured by MXD Process are equipped with a needle valve at the inlet port. By adjusting that valve you can control the speed of the mixer. The maximum rpm, torque and air flow requirements for each of the air motors offered by Mixer Direct are given in the table below.

Table 1. Maximum Rpm, Torque and Air Flow

Nominal Horsepower	Max RPM	Torque (in-lb)	Max Air Flow (cfm)
1/2	10,000	2.8	20.5
3/4	3,000	19.5	30.0
1 1/2	3,000	36.0	78.0
4	3,000	84.0	128.0

It is highly recommended to perform regular maintenance on industrial equipment to ensure its longevity and optimal functionality. In order to achieve this, it is essential to inspect and lubricate the equipment at regular intervals. Prior to conducting any maintenance or wiring procedures on electrical equipment, it is imperative to de-energize all power and lock it out to prevent any potential hazards.

To maintain your mixer, follow these guidelines:

- Maintain a clean mixer to prevent the accumulation of debris or residue.
- Regularly inspect all wiring and repair any issues promptly to avoid further damage or hazards.
- Check all fasteners and set screws periodically to ensure their tightness to prevent loosening during operation.
- For air motor powered units, it is recommended to keep the air supply dry and ensure that oil is present in the lubricator to prevent overheating and reduce wear and tear.

Gearbox Lubrication

All gearbox-driven units are thoroughly tested before shipping and are filled with the appropriate amount of lubricant. These units are suitable for use in ambient temperatures ranging from 30°F to 104°F. Please refer to the gearbox manual or read the following excerpts for servicing instructions.

The vent plug is optional for high load applications. Prior to operating the equipment, it is advised to note the orientation of your gearbox and to substitute the vent plug with the solid plug in the designated location, as marked by arrows indicating recommended vent plug positions. This will ensure optimal performance and safety measures are upheld.

Please ensure that all electrical and mechanical power sources are turned off and securely locked out to prevent any accidental energization or activation.

It is recommended to change the oil while it is still warm.

It is advisable to conduct regular inspections to identify any signs of oil leakage.

When performing oil changes, please follow these steps:

- Disassemble the gearbox from the mixer.
- Remove drain/fill plug from housing.
- Drain all oil and clean the inside of housing.
- Dispose of oil responsibly, following environmental guidelines.
- Please ensure that you fill the gearbox with the appropriate type and quantity of oil. See Table 2. Standard Lubricant Types and Capacity below.
- Install the drain/fill plug back into the housing and tighten.

Table 2. Standard Lubricant Types and Capacity

Standard Lubricant Types		Oil Capacity
Sterling	AGMA #4 / ISO 150	Size 1 - 11 fl oz
IPTS		
JIE	Mobil ISO VG 220	Size 2 - 14 fl oz

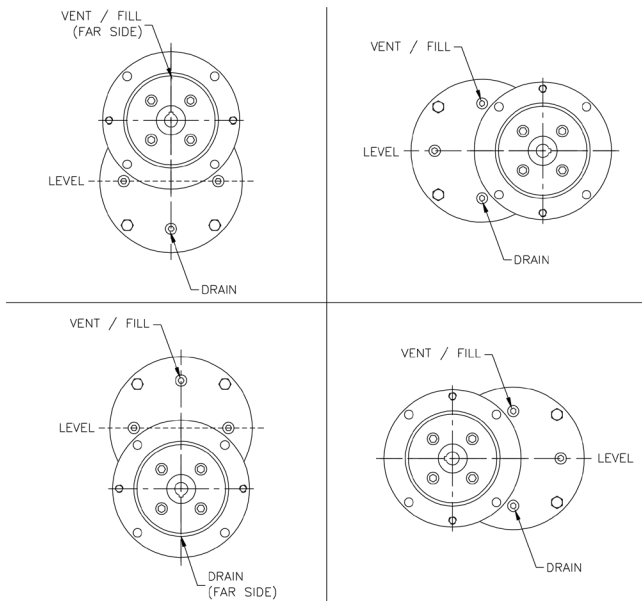

Figure 14. Drain and Fill Ports

Shaft Runout Check

CAUTION
AVOID DAMAGE!
It is strongly advised to abstain from utilizing heat or an open flame for the purpose of straightening the shaft. Such an approach is likely to result in irreparable distortions that may render the shaft unusable.

Ensuring that the mixing shaft is straight is crucial to prevent excessive vibrations and extend lifespan of the mixer. The runout of the mixing shaft should not exceed 0.002 in Total Indicated Runout (TIR) per foot. Refer to the diagrams provided to straighten the shaft as necessary.

ATTENTION: TOLERANCE = 0.002 in RUNOUT PER FT

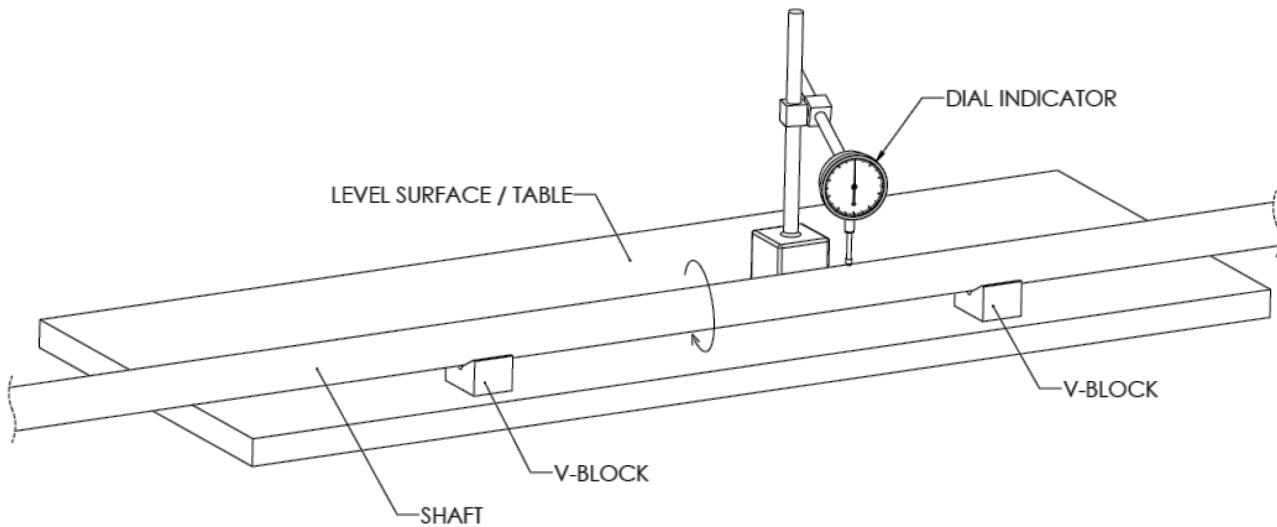

Figure 15.

1. Verify runout does not exceed 0.002 in by rotating the shaft and observing the dial indicator.

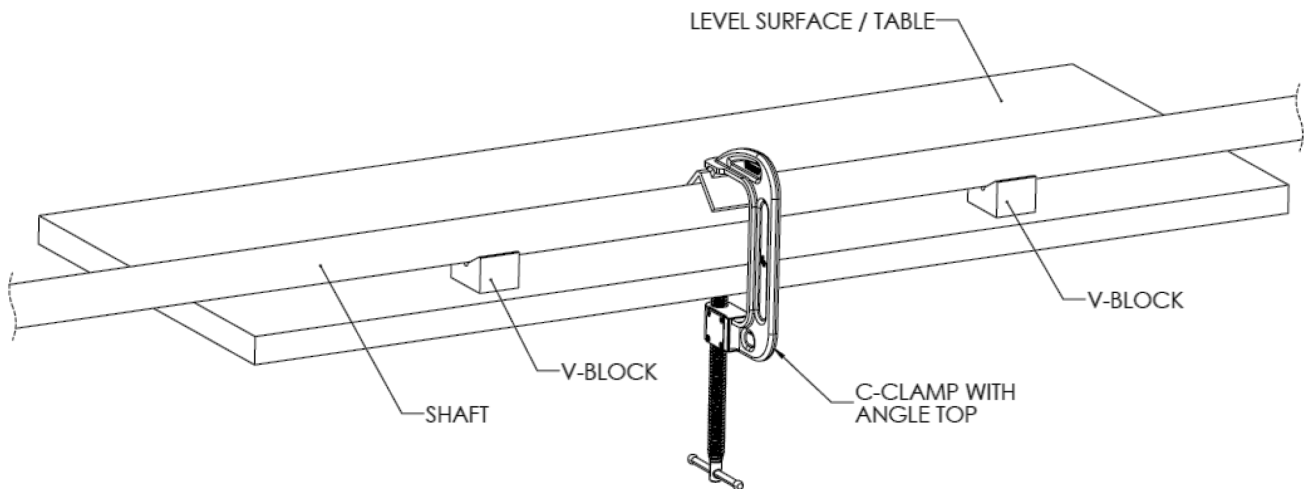

Figure 16.

2. If the shaft runout exceeds specifications, gently apply force to high spots using a C-clamp to bring the shaft within tolerance.



Seal and Bearing Replacement

Bearings and seals in the bung mount may wear out over time and should be replaced to reduce vibrations and extend the mixer's lifespan.

Removal

1. Remove the shaft (2) from the cone assembly (1).

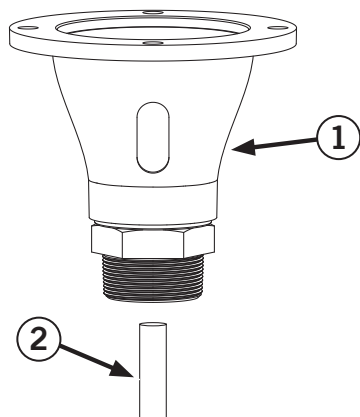

Figure 17.

2. Remove the cone from the direct drive motor or gearbox.

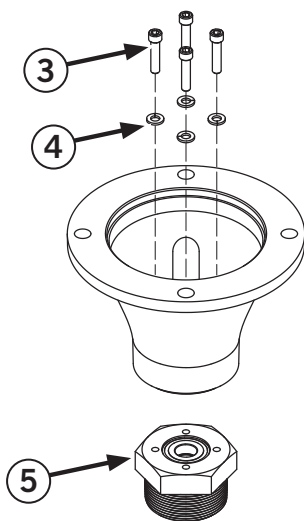

Figure 18.

3. Remove four socket head cap screws (3) and four washers (4) separating the cone from the bung mount (5).

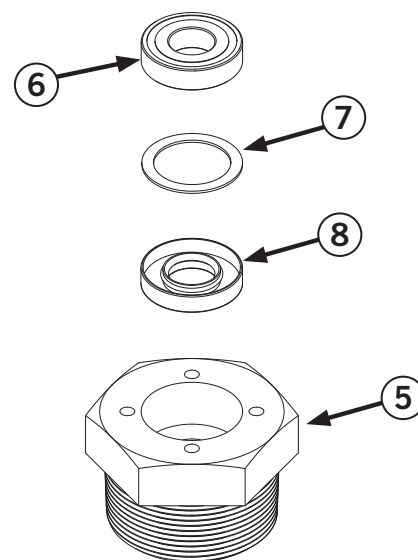

Figure 19.

4. Press out the bearing (6) shim (7), and seal (8) from the bung mount (8).

Installation

Important: Do Not reuse old bearing and seal when removed. Always replace with a new bearing and seal.

Lip seals are devices that provide one-way sealing, which means they can only seal pressure from one direction. Therefore, it is crucial to install them correctly based on the application requirements of vessel pressure or vacuum. The lip seals will seal pressure in the direction in which the lip(s) are pointed. For vacuum applications (external pressure), the seal lips should be pointed up/out, and for internal pressure, the seal lips should be pointed down/in.

NOTICE

When installing a shaft through a lip seal, be careful not to damage the seal. Ensure that the shaft is smooth and use lubricant. Chamfer the end/shoulder of the shaft at a 10-20° angle to prevent it from getting caught on the seal.

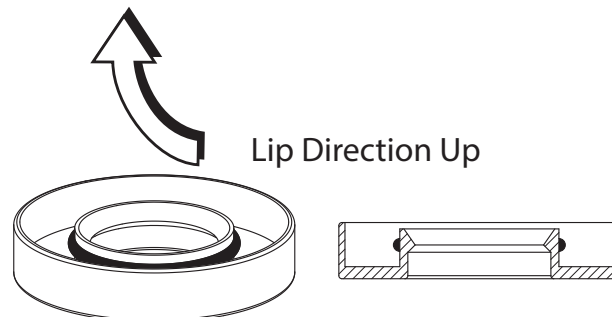

Figure 20.

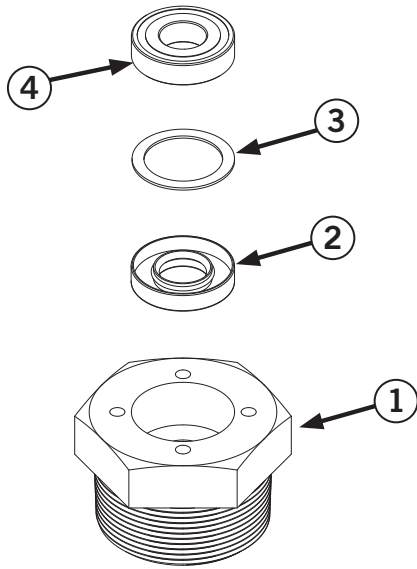

Figure 21.

1. Press the seal (2) into the bung mount (1).
2. Install a shim (3) on top of the seal in the bung mount.
3. Press the bearing (4) until flush with the top of the bung mount.

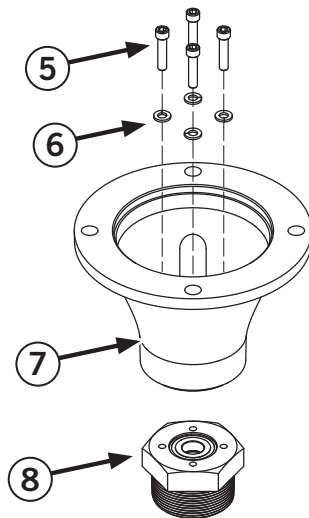

Figure 22.

4. Install the bung mount (8) to the cone (7), and install four washers (6) and four socket head cap screws (5).
5. Tighten to specifications. See "Information Tables" on page 28.
6. Install the cone to the direct drive motor or gearbox.

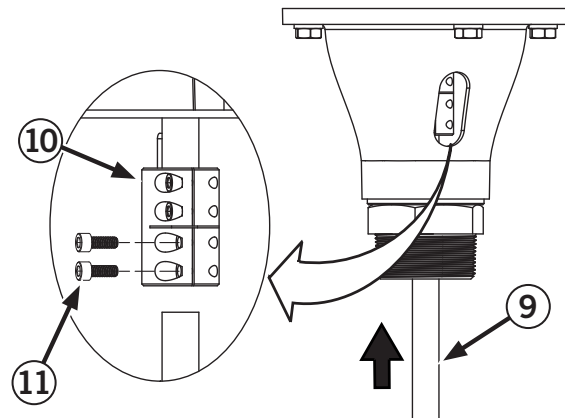

Figure 23.

1. Install the shaft (9) to the shaft coupler (10) located in the cone assembly.
2. Install and tighten two socket head cap screws (11). Tighten to specifications. See "Information Tables" on page 28.

Troubleshooting Guide

PROBLEM	POSSIBLE CAUSE	SUGGESTED SOLUTION
Incorrect mixer rotation	Incorrect wiring to motor	Swap any two line-wires to reverse rotation. Refer to Motor Wiring Section for help.
	Incorrect plumbing to motor	Reverse the inlet and exhaust plumbing.
Shaft will not seat fully	Coupler screws too tight	Loosen coupler screws
	Damaged shaft	Repair or replace shaft
Mixer will not start	Incorrect wiring	Check wiring diagram and wire correctly
	Loose connections	Tighten connections
	Blown fuse	Replace fuse
	Impeller interference	Free all debris for rotation
	Damage to motor	Service or replace motor (consult factory)
	VFD Malfunction	Refer to VFD Manual
Mixer will not reach correct speed	Overload of motor	Check amperage against nameplate data
	Damage to gear reducer	Repair/replace reducer
	VFD Malfunction	Refer to VFD Manual
	Insufficient air pressure and flow	Remove supply air line restrictions.
		Adjust regulator
	Clogged exhaust	Clean/clear exhaust muffler
Worn out air motor	Replace or rebuild motor	
	Check oil supply	
Noisy	Insufficient lubricant	Fill proper amount of lubricant
	Foreign material in lubricant	Change lubricant
	Incorrect lubricant	Change to correct lubricant
	Worn or faulty bearings or gears	Replace bearings and/or gearbox
	Incorrect gearbox and bearing alignment	Adjust/align bearings and gearbox
	Bent/broken guards	Straighten/replace guards
Bearing failure	Bearing has worn beyond useful life See all items under "Noisy"	Replace bearing (check all other parts)
Gear failure	Excessive loading (check amps)	Consult factory
	Lack of or improper lubrication	Fill with recommended lubricant or equivalent (see above)
	Start-stop-start loading (product burying impeller with solids)	Free impeller of any solids at startup
	Foreign material in lubricant	Replace lubricant
Oil leakage	Excessive lubricant	Check manual for proper amount of lubricant and drain excess
	Damaged/broken gasket	Replace gasket
	Seals worn or damaged	Replace seals
	Vent not installed/clogged	Replace seals – install/unclog vent
Shaft vibration	Impeller not immersed in liquid	Fill tank
	Bent mixer shaft	Consult factory
	Loose or improperly assembled	Assemble shaft securely
	Damaged bearings	Check and replace bearings if necessary
	Debris on impeller	Clean impeller
	Loose or bent impeller blades	Tighten or straighten blades (consult factory)
	Operating at critical speed	Decrease or increase speed until vibration is reduced
Seal leakage	Worn seal	Replace seal
	Scored shaft	Replace shaft
	Incorrect seal position	Consult factory



Diagrams and Spare Parts

Direct Drive

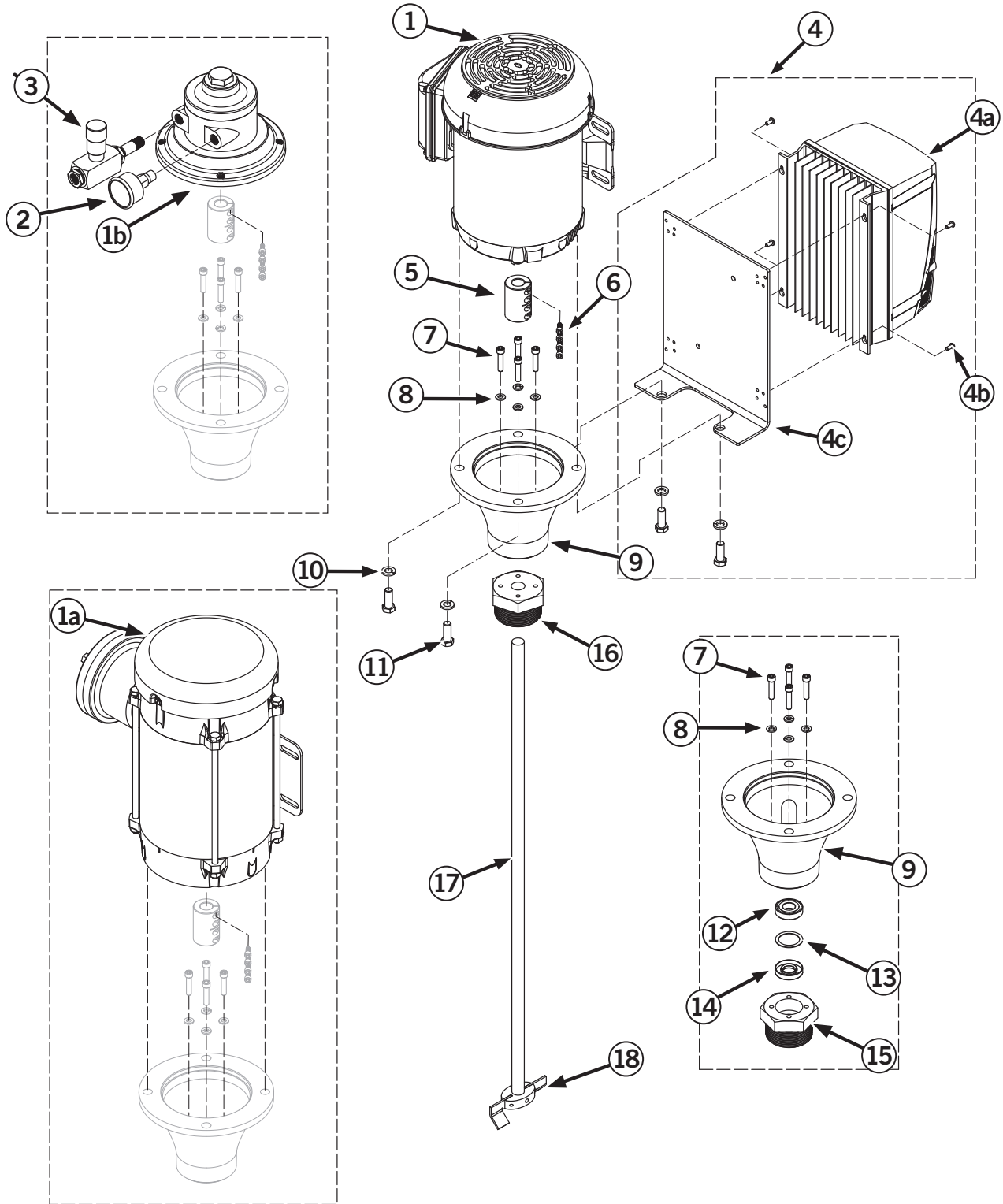

Figure 24. Direct Drive



Table 3.

ITEM	QTY	DESCRIPTION
1.	1	Standard Electric Motor
1a.	1	XP Motor
1b.	1	Air Motor
2.	1	Muffler
3.	1	Air Valve Assembly
4.	1	Optional Variable Frequency (VFD) Assembly
4a.	1	Variable Frequency Drive (VFD)
4b.	4	#8-32 x 3/8" Round Head Screw
4c.	1	VFD Mount Plate
5.	1	Shaft Coupler
6.	4	Socket Head Cap Screw
7.	4	1/4"-20 Socket Head Cap Screw, 1-1/8" Long (aluminum cone), 3/4" long (stainless cone)
8.	4	Split Washer
9.	1	Aluminum/Stainless Steel Cone
10.	4	Split Washer
11.	1	3/8"-16 x 1" HHCS
12.	1	Ball Bearing 5/8"
13.	1	Seal Bearing Shim 5/8"
14.	1	Oil Seal 5/8"
15.	1	Bung Mount
16.	1	Bung Mount
17.	1	Shaft 5/8"
18.	1	Impeller (qty. dependent on model)

Gearbox Drive

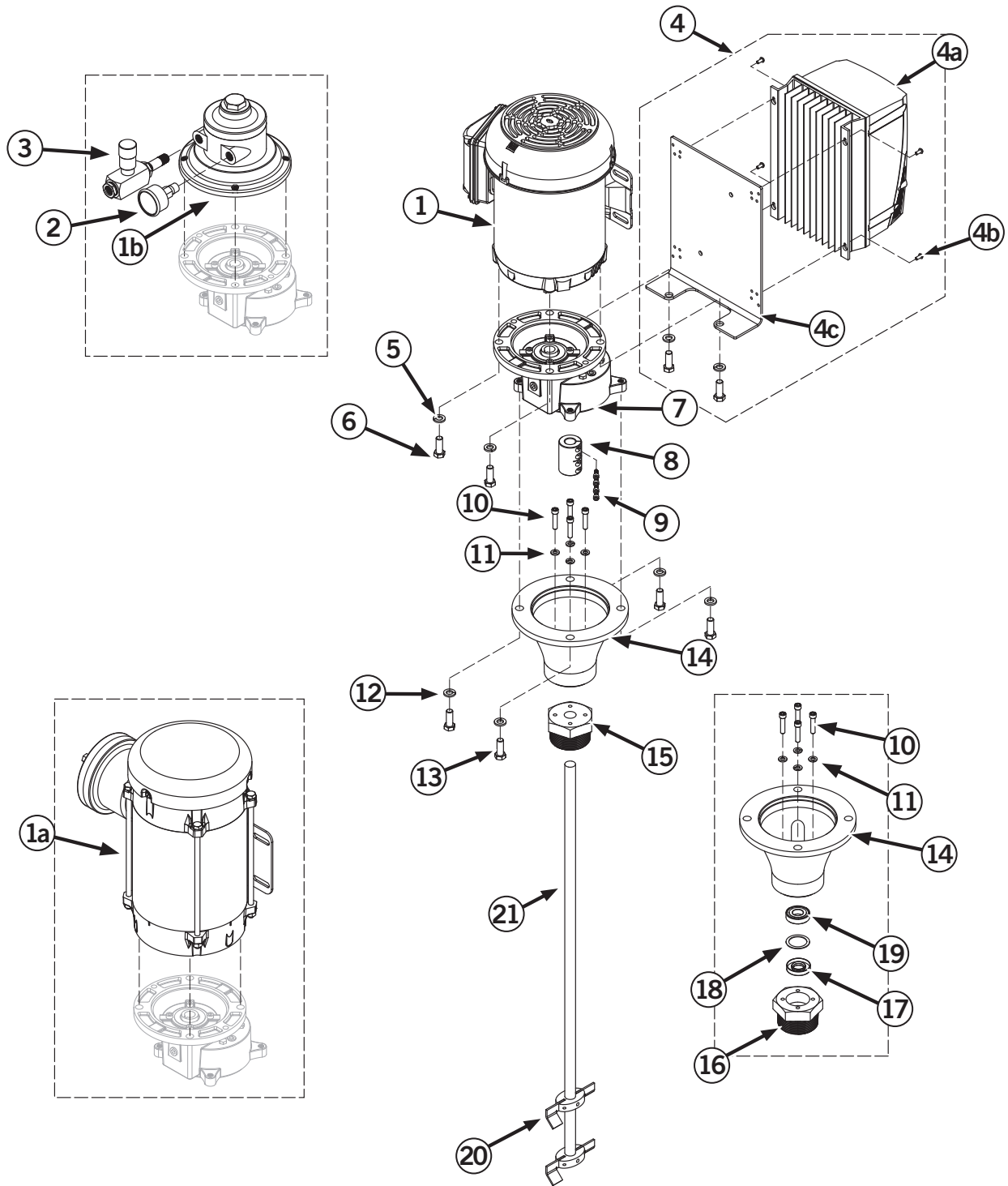

Figure 25. Gearbox Drive



Table 4.

ITEM	QTY	DESCRIPTION
1.	1	Standard Electric Motor
1a.	1	XP Motor
1b.	1	Air Motor
2.	1	Muffler
3.	1	Air Valve Assembly
4.	1	Optional Variable Frequency (VFD) Assembly
4a.	1	Variable Frequency Drive (VFD)
4b.	4	#8-32 x 3/8" Round Head Screw
4c.	1	VFD Mount Plate
5.	4	Split Washer
6.	4	3/8"-16 x 1" HHCS
7.	1	Gear Box
8.	1	Shaft Coupler
9.	4	Socket Head Cap Screw
10.	4	1/4"-20 Socket Head Cap Screw, 1-1/8" Long (aluminum cone), 3/4" long (stainless cone)
11.	4	Split Washer
12.	4	Split Washer
13.	4	3/8"-16 x 1" HHCS
14.	1	Aluminum/Stainless Steel Cone
15.	1	Bung Mount
16.	1	Bung Mount
17.	1	Oil Seal 5/8"
18.	1	Seal Bearing Shim 5/8"
19.	1	Ball Bearing 5/8"
20.	1	Impeller (qty. dependent on model)
21.	1	Shaft

Information Tables

Torque Specifications

NOTE: All values are for coarse thread lubricated fasteners

Table 5. Cap Screw and Screw Torque Values

	Nominal Size	SAE J429	SAE J429	ASTM A574	ASTM F593
		Grade 5	Grade 8	SHCS	304/316 SS
INCH LBS	#10	31	44	50	20
	#12	49	70	79	29
	1/4	76	107	120	62
	5/16	156	221	249	128
FOOT LBS	3/8	23	32	36	19
	7/16	36	52	58	30
	1/2	57	80	90	46
	5/8	113	159	179	92
	3/4	200	283	318	113
	7/8	322	455	512	182
	1	483	682	767	273
	1-1/8	684	966	1086	346
1-1/4	965	1363	1533	545	

Table 6. Clamp Coupling and Coupler Torque Values

	Largest Bore	Screw	Alloy Steel	Stainless	Hex Size
INCH LBS	3/8	#6-32	28	15	7/64
	1/2	#8-32	49	28	9/64
	5/8	#10-32	76	45	5/32
	3/4	1/4-28	170	110	3/16
	7/8	1/4-28	170	110	3/16
	1	1/4-28	170	110	3/16
	1-1/4	1/4-28	170	110	3/16
	1-1/2	1/4-28	170	110	3/16
FT LBS		5/16-24	27	15	1/4
		3/8-24	47	28	5/16

Table 7. Set Screw Torque Values

	Nominal Size	Alloy Steel	Stainless	Hex Size
INCH LBS	#8	20	13	5/64
	#10	36	23	3/32
	1/4	87	57	1/8
	5/16	165	107	5/32
FOOT LBS	3/8	24	16	3/16
	7/16	35	23	7/32
	1/2	52	34	1/4
	9/16	52	34	1/4
	5/8	110	72	5/16
	3/4	200	130	3/8
	7/8	300	195	1/2
	1	417	271	9/16



Page Intentionally Left Blank



4650 New Middle Road Jeffersonville, IN 47130

Call Us: (812) 202-4047

Fax: (888) 811-4823

www.mxdprocess.com
[LinkedIn](#)